



Neutral Citation Number: [2023] EWHC 716 (Pat)

HP-2020-000035

Case No: HP-2020-000035

IN THE HIGH COURT OF JUSTICE
BUSINESS AND PROPERTY COURTS OF ENGLAND AND WALES
INTELLECTUAL PROPERTY LIST (ChD)
PATENTS COURT

Royal Courts of Justice, Rolls Building
Fetter Lane, London, EC4A 1NL

Date: 30 March 2023

Before :

HIS HONOUR JUDGE HACON

Between :

AUTOSTORE TECHNOLOGY AS

Claimant

- and -

- (1) OCADO GROUP PLC**
- (2) OCADO RETAIL LIMITED**
- (3) OCADO SOLUTIONS LIMITED**
- (4) OCADO INNOVATION LIMITED**
- (5) OCADO OPERATING LIMITED**
- (6) THARSUS GROUP LIMITED**

Defendants

Vernon Flynn KC, Adrian Speck KC, Nicholas Saunders KC, Kathryn Pickard, Miles Copeland, Georgina Petrova and Thomas Lunt (instructed by Kirkland & Ellis International LLP) for the Claimant

Iain Purvis KC, Piers Acland KC, James Segan KC and Tom Alkin (instructed by Powell Gilbert LLP) for the Defendants

Hearing dates: 15-18, 21-22, 29-31 March 2022, 4 and 11-12 April 2022

Approved Judgment

This judgment was handed down remotely at 5pm on 30 March 2023 by circulation to the parties or their representatives by email and released to the National Archives.

.....

HIS HONOUR JUDGE HACON

Judge Hacon :

INTRODUCTION

1. The Claimant (“AutoStore”) is a Norwegian company that has been a pioneer in automated warehouse technology. Its growth was largely powered by the invention and development of an automated system for storing and retrieving containers in a warehouse, a system known as the “AutoStore ASRS”. The letters stand for automated storage and retrieval system. Rails forming a grid are installed at the top of the warehouse. Robots travel along the rails, in X and Y directions. They park and retrieve containers which are stacked below in vertical piles.
2. AutoStore ASRS enabled a higher density of storage than had previously been possible with commensurate savings in warehouse size and associated costs. The first commercial use of AutoStore ASRS was in 2005. Since then, the system has been installed in more than 800 locations in 45 countries.
3. The most significant modification in AutoStore ASRS since 2005 has been in the design of the robots. The original robots were known as “Red Line” robots. More recently AutoStore has designed and developed “Black Line” robots, which are covered by the patents in issue in these proceedings.
4. The first defendant develops automated systems for use in large scale grocery businesses. The second defendant is a joint venture between the first defendant and Marks & Spencer plc. It operates an online grocery business in the UK under the “Ocado” brand name, including the fleet of Ocado vans which deliver the groceries to the homes of customers. The first defendant operates the system used by the second defendant. The third defendant markets the technology to supermarkets outside the UK. The fourth defendant owns IP rights relating to the technology. The sixth defendant develops and makes robots used by the second defendant. The first five defendants are all part of the same Ocado group of companies. The sixth defendant is not, but it is convenient to refer to all the defendants as “Ocado”.
5. Ocado is a former customer of AutoStore’s. Ocado purchased a Red Line system in 2012. Ocado has since developed its own system, known as the Ocado Smart Platform, or “OSP”.
6. The OSP system and the robots it uses are alleged by AutoStore to infringe the two principal patents in suit. These are EP (UK) No. 2 928 794 (“EP 794”) and EP (UK) No. 3 070 027 (“EP 027”), both owned by AutoStore.
7. Beyond findings of non-infringement in relation to AutoStore’s allegations of infringement, Ocado further seek certain declarations of non-infringement (“DNIs”) discussed further below.

SPLIT TRIAL

8. The trial was heard in two parts. The first part concerned two alleged prior disclosures of the inventions claimed in the patents in suit. It was not in dispute

that the disclosures were made; the point in issue was whether either or both were made under a binding obligation of confidence. This turned largely on identifying the law which governed the disclosures. In this part of the trial, Vernon Flynn KC and Georgina Petrova appeared for AutoStore; James Segan KC for Ocado.

9. In the other part of the trial, concerning what were described as the technical issues, Adrian Speck KC, Nicholas Saunders KC, Kathryn Pickard, Miles Copeland and Thomas Lunt appeared for AutoStore; Iain Purvis KC, Piers Acland KC and Tom Alkin appeared for Ocado.

THE WITNESSES

Prior Disclosure

10. AutoStore called three witnesses of fact and two expert witnesses on foreign law.
11. Evgenii Konstantinov is a co-founder of EVS, Ooo (“EVS”), a company based in St Petersburg, and is its Deputy General Director. He gave evidence about the relationship between AutoStore, EVS and the Central Bank of the Russian Federation (“the Bank”), with interpretation from Russian. Not much of his evidence was central to the issues. In cross-examination he gave short, clear answers.
12. Michael Kutsenko is the former Head of International Development at EVS. He was the contact at EVS for communications between AutoStore and EVS and attended a key meeting. Mr Kutsenko spoke good English and he too gave brief, clear answers, which were always to the point. He was a very good witness.
13. Sven Åge Hjorteland is AutoStore’s Vice President of Sales. He was the AutoStore contact in the dealings with EVS and the Bank. He gave his evidence in excellent English and was a helpful, straightforward witness.
14. AutoStore’s expert witness on Russian law was Professor Peter Maggs. Professor Maggs is a Research Professor at the University of Illinois. He specialises in the law of the Russian Federation. He is the author, co-author, co-editor, translator or co-translator of what he described as a dozen articles on Soviet and Russian law, including a translation of the Russian Civil Code.
15. I am sure that Professor Maggs was trying to help the court, but occasionally he avoided giving a clear answer to a straightforward question, as if reluctant to be pinned down to an answer unhelpful to AutoStore. There is a particular matter about his evidence I must raise. In his report he said that he had given evidence as an expert on Russian law, including various cases before English courts. He referred to *OJSC TNK-BP Holding v Lazurenko* [2012] EWHC 2781 (Ch) in which Professor Maggs gave evidence about Russian law on confidentiality. The claimant, TNK-BP alleged that the defendant, Mr Lazurenko, had been in breach of both contractual and equitable obligations of confidence. The Chancellor, Sir Andrew Morritt, ruled that these causes of action were governed by Russian law and found that the equitable and contractual obligations were to

be treated as being the same. Professor Maggs acted as an expert witness on Russian law for Mr Lazurenko. The expert witness for TNK-BP stated that in order to protect commercial confidential information it was necessary for there to be compliance with the Russian Federation Law “on commercial secret”, the Commercial Secrecy Law. The Chancellor quoted this part of Professor Maggs’ evidence in response:

“Yes, I generally agree with Mr Rozenburg. In order for information to be confidential and protected, the holder of a commercial secret must take special steps to preserve confidentiality. Among other things, the holder must expressly identify the information comprising its commercial secrets, must mark documents containing such information as “Commercial Secret of [name of holder of the secret]”. If these precautions are not taken, confidentiality is lost.”

16. That evidence is difficult to reconcile with what he said in his report in this case, on a point that could have been of some significance. When challenged in cross-examination, Professor Maggs said that as best he could recall he was giving evidence in *TNK-BP* about a claim under the Commercial Secrecy Law, not a claim of confidence under the law of contract. But as the Chancellor made clear, the claim was to a contractual (and equitable) obligation of confidence. It would have been far better had Professor Maggs given prominence to his evidence in *TNK-BP* from the start, together with an explanation in his report for what appeared to be inconsistent evidence now. Failure to do this did not improve confidence.
17. Are Stenvik gave evidence for AutoStore on Norwegian law. He is a partner at the law firm BAHR in Oslo and is Head of the Intellectual Property Law practice group. There was little dispute about Norwegian law and he was cross-examined only briefly. He gave clear, authoritative answers.
18. Ocado called no witnesses of fact. They called two expert witnesses on Norwegian law, Professor Harald Irgens-Jensen and Professor Guiditta Cordero-Moss. Professor Irgens-Jensen is from the Department of Private Law at the University of Oslo; Professor Cordero-Moss is from the same department at Oslo University. Neither was cross-examined. AutoStore contended that Professor Cordero-Moss’s evidence was inadmissible because it was premised on a hypothetical factual situation that is irrelevant to the issues in dispute. I have not found it necessary to rely on Professor Cordero-Moss’s evidence.
19. Ocado’s expert on Russian law was Maxim Kulkov. Mr Kulkov is the managing partner at KK&P Trial Lawyers, a firm he established in Moscow. Previously he headed the Russian dispute resolution practice at Freshfields Bruckhaus Deringer LLP, Goltslat PLP and Pepelyaev, Goltsblat and Partners. Mr Kulkov has been in practice as counsel for over 26 years and has also sat as an arbitrator in centres in Russia and in Stockholm. Mr Kulkov gave one or two slightly surprising answers relating to unimportant matters, which may have been because he was not giving evidence in his native Russian. Generally, I thought he was a very good witness, stating his views in clear and direct terms.

Technical issues

20. AutoStore filed evidence from two expert technical witnesses. The first was Stephen Knights who has worked for over 30 years in logistics automation and material handling systems. He was not cross-examined. His role was to supplement the evidence of AutoStore's principal expert, Professor David Limebeer, principally in relation to the person skilled in the art and their common general knowledge at the relevant time.
21. Professor Limebeer is a Distinguished Professor of Control and Systems Engineering at the University of the Witwatersrand, Johannesburg. He is also Emeritus Professor of Control Engineering in the Department of Engineering Science at the University of Oxford and Emeritus Fellow of New College, Oxford.
22. Professor Limebeer gave clear, helpful evidence and was, I am sure, entirely honest in his opinions. As with any witness of his (and Professor Fottner's) eminence in his field, there was a risk of taking an over-inquiring interest in the technical issues and thereby stating a view as he would have perceived it, as opposed to how the skilled person would have done. For the much greater part, I think Professor Limebeer succeeded in communicating his idea of the skilled person's perspective.
23. Ocado's principal expert witness was Professor Johannes Fottner. He is Professor of Logistics Engineering and Full Professor of the Chair of Materials Handling, Materials Flow and Logistics at the Technical University of Munich. Professor Fottner for the most part gave short, clear answers and I am sure that for the whole part was expressing his honestly held views. To some degree, like Professor Limebeer, Professor Fottner was a man who was at risk of moving outside the perspective of the skilled person, but I think that he, too, where it was important, successfully avoided this.
24. There was also written expert evidence from Professor Chris Gerada, who is a Professor of Electrical Engineering at the University of Nottingham. Professor Gerada was not cross-examined.

THE SKILLED PERSON

25. It was common ground that the skilled person is a mechanical engineer with a background in vehicle design, robotics and/or automation. He or she would have experience of working with ASRS systems. There may be a team, including a logistics engineer who would have skills required to deal with the logistics involved in the storage and retrieval of a wide variety of products in a warehouse. Alternatively, it may be that the mechanical engineer would have acquired these skills. It makes no difference and for convenience I will speak of the skilled person, singular, assumed to have the necessary knowledge of logistics.

THE COMMON GENERAL KNOWLEDGE

26. At the priority date of the patents in suit, 10 December 2012, the skilled person would have known that two criteria determined how effective a warehouse storage system was. First, the speed of throughput, i.e. storage and retrieval. Secondly, how much storage capacity was made available per unit area.
27. Broadly, there were two arrangements for storing goods. The first used shelves in vertical arrays with aisles between them. Forklift trucks or other transport means located in the aisles were used to deposit goods on the shelves and to collect them. The advantage of using shelves was that any item was easily accessed, allowing high throughput. The disadvantage was the need for space between the goods and the shelf above and the space taken up by the aisles. This reduced capacity. To some extent capacity could be improved by storing goods two or more units deep on the shelf, but that reduced speed of access.
28. By December 2012 some shelf systems were automatic in the sense that there was no need for forklift trucks and the relatively wide aisles they required. “Stacker cranes”, cranes with a tall mast, travelled along narrow aisles to retrieve pallet loads. Horizontal conveyors at floor level moved the pallets to and from a desired location. This is shown below:

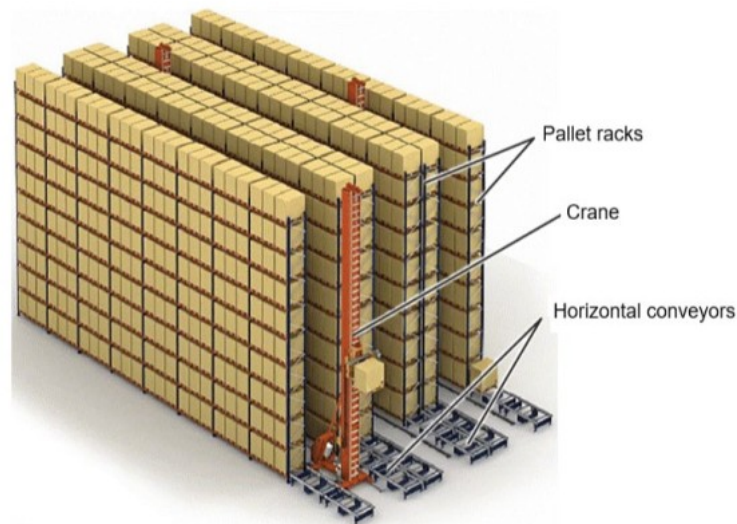

29. Another arrangement used a “stacking system”. Items were stacked on top of each other without shelves. These could be the goods themselves, goods on pallets or goods in boxes. An overhead crane would access the items from above. This permitted high storage density. On the other hand, only the top item in each stack was rapidly accessed. It took longer to retrieve, or to place items lower in the stack because of the need to move higher items aside and back again. Also, items low in the stack had to be strong enough to bear the weight of those above.
30. The AutoStore Red Line system has special relevance. It was within the common general knowledge (CGK) of the skilled person at the priority date. It is a stacking system with columns that define vertical zones within which goods are stacked. At the top of the columns is a grid of rails on which robots run. The system is shown below:

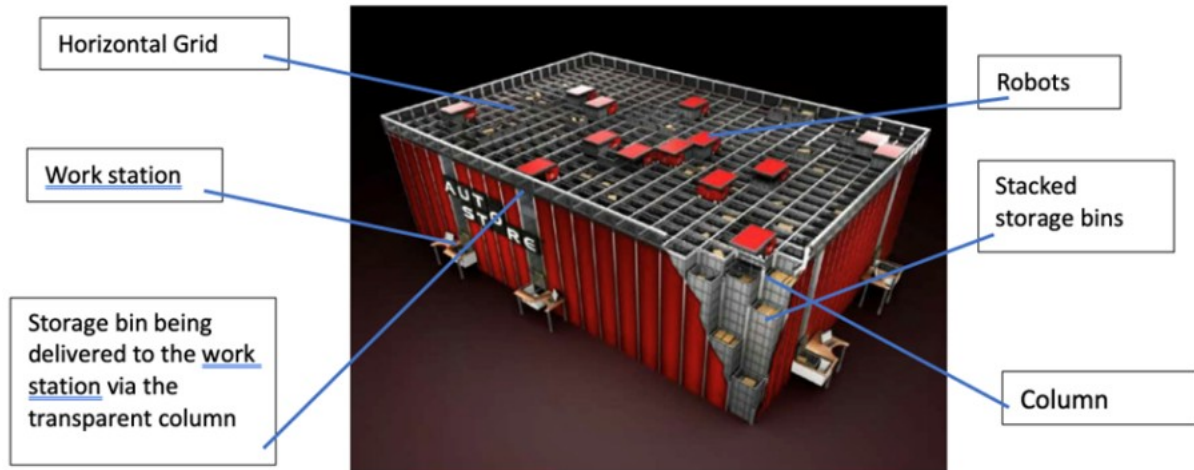

31. In the near-facing side there are transparent columns, two as shown. These are used to allow a robot at the top of the column to lower a storage bin down to a manned workstation at floor level, where the robot's gripper releases the bin. Similarly, a bin is lifted from the workstation up to the top level via the transparent column for onwards transportation by a robot to a selected storage location.
32. Red Line robots are of a cantilever design. The top of the robot extends beyond the main body. The robot's gripper, and when in use the bin held by the gripper, are located beneath the extended portion of the top. Because of this cantilevered design, two robots cannot access adjacent columns end-to-end:



33. AutoStore's Red Line system uses double rails to allow robots to pass each other side-to-side over adjacent storage columns. This was therefore part of the CGK, at least in the context of that system. It is more clearly shown below:



34. There was no need for double rails in both directions and this was not part of the CGK.

THE PATENTS

The Central Cavity Patents

35. The patents principally in suit were referred to as the “Central Cavity Patents” after a feature of the robots covered by the claims: they have a central cavity which plays an important part in the inventive concept.
36. There are two Central Cavity Patents remaining in the case: the parent, EP 794 and a divisional, EP 027. They share the priority date of 10 December 2012. At the trial it was sufficient for evidence and argument to consider the description of EP 794 only.

The remaining patents

37. The remaining patents in issue are EP (UK) 3 050 824 (“EP 824”) and EP (UK) 3 250 481 (“EP 481”). No allegation of infringement is made by AutoStore in respect of these, but Ocado seeks declarations of non-infringement.

THE CENTRAL CAVITY INVENTION

38. The invention is introduced in this way at the start of the specification of EP 794:

“[0001] The present invention relates to a remotely operated vehicle for picking up storage bins from a storage system as defined in the preamble of claim 1. The invention also relates to a storage system using the inventive vehicle.”

39. The role of the central cavity is best seen by distinction from AutoStore’s Red Line robots. The latter are shown in Figure 2 of EP 794:

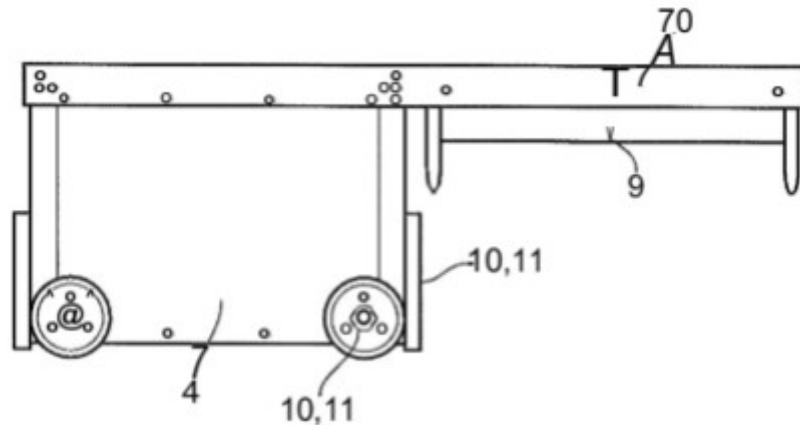

40. The wheels of the Red Line robots, 10 and 11, attached to the main body 4, are aligned to run on either the X or Y rails of the system. When the robot is running along the X rails, the Y wheels are raised and vice versa. The containers to be moved are held by a lifting device 9 which is supported by the overhanging portion of a bar 70.
41. The specification of EP 794 identifies disadvantages with this cantilever arrangement in paragraph [0001]:

“Firstly, the particular design of the robot prevents access to all off the available storage columns in the storage system. Furthermore, this particular design may cause an undesirable high torque during lifting and transportation of storage bins, thereby creating potential instability problems, as well as a clear limitation of the robots maximum handling weight. An additional disadvantage caused by the prior art robot design is the fact that only one particular bin and one particular bin height may be accepted for each type of robot in order to ensure adequate stability. Finally, the presence of an integrated yoke/overhang in the upper part of the section receiving the storage bin necessitates an undesired speed reduction at the final stage of the lifting process performed by the yoke suspended vehicle lifting device. The object of the present invention is to solve, or at least substantially alleviate, the above-described disadvantageous [sic], that is to provide a vehicle/robot with higher stability properties, higher maximum handling weights, a more effective use of available space during operation and a less time-consuming lifting and transporting process of storage bins.”

42. The solution is to store the container in a central cavity of the robot. This is figure 3 of EP 794, which shows an embodiment of the invention:

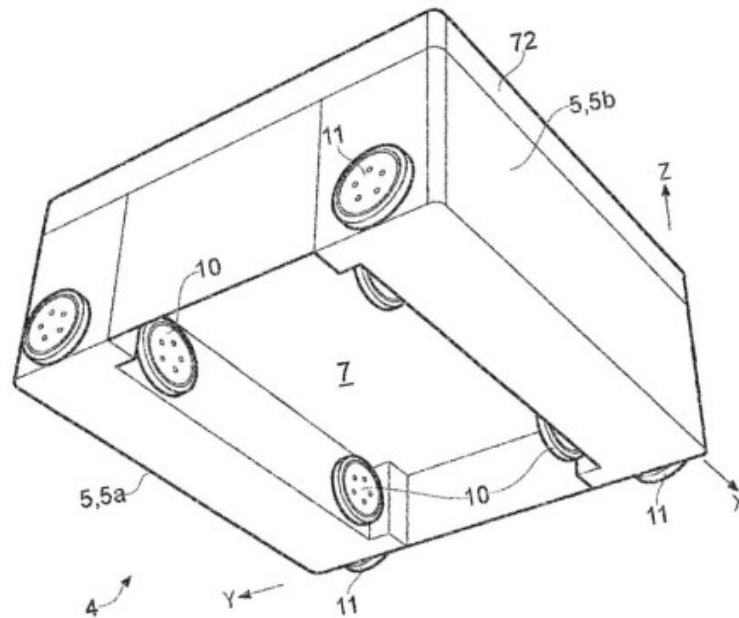

43. As before there are two sets of wheels. The wheels 10 run along the X rails, at which time the wheels 11 are raised. When the robot is moving along the Y rails using wheels 11, wheels 10 are raised. A storage bin is raised by a lifting device (not shown) into cavity 7 where it is kept during transportation.

44. The description at paragraph [0002] divides the vehicle body into two sections:

“... a first section for storing vehicle driving means and a second section for receiving any storage bin”

45. Figure 3 above shows that one set of wheels is mounted inside the cavity, while the other set are mounted on the exterior walls of the body of the robot. This is described in paragraph [0003] as a characterising feature of the invention:

“... at least one of the two sets of vehicle rolling means [i.e. wheels] is arranged fully within the body.”

46. Figure 3 is said to be a view of a vehicle according to the invention, by implication one embodiment. An issue in the case turns on the position of the “X” wheels 10 and whether their being “fully within the body” means they must be substantially where they are shown to be in figure 3 or whether alternative positions are possible “fully within the body”. I return to this below.

47. Figure 3 also shows that the body has “side parts”, 5a and 5b, on opposite sides of the cavity. Paragraph [0007] describes a preferred embodiment, the same as that shown in figure 3 and the only one illustrated. Placing one set of wheels within the robot body means that the side parts of the body extend beyond the cross-sectional area of the storage column above which the robot is located:

“In a preferred embodiment the vehicle body covers less or equal to the lateral cross sectional area of one central storage column in the first direction (X) and covers the lateral cross sectional area of more than one

central storage column in the second direction (Y) during use. In a more specific example the vehicle body extends beyond the lateral cross sectional area of the central storage column at both sides facing the second direction (Y), i.e. covering also some of the cross sectional areas of the adjacent storage columns extending in the second direction (Y). The degree of extension from the central storage column is preferably equal on both of these sides. Central storage column is defined as the storage column which is immediately below a robot when the latter has reached a position allowing pick-up of a storage bin.”

48. Figure 8 of EP 794 shows a robot on the rails at the top of the warehouse with the lifting device 9 lowered into a storage column 8a, one of the many created by the ASRS grid 15. When lowered further, the lifting device would become attached to a container (not shown) which is then lifted into the central cavity of the robot. The robot subsequently moves along the X and/or Y rails to the desired location for depositing the container:

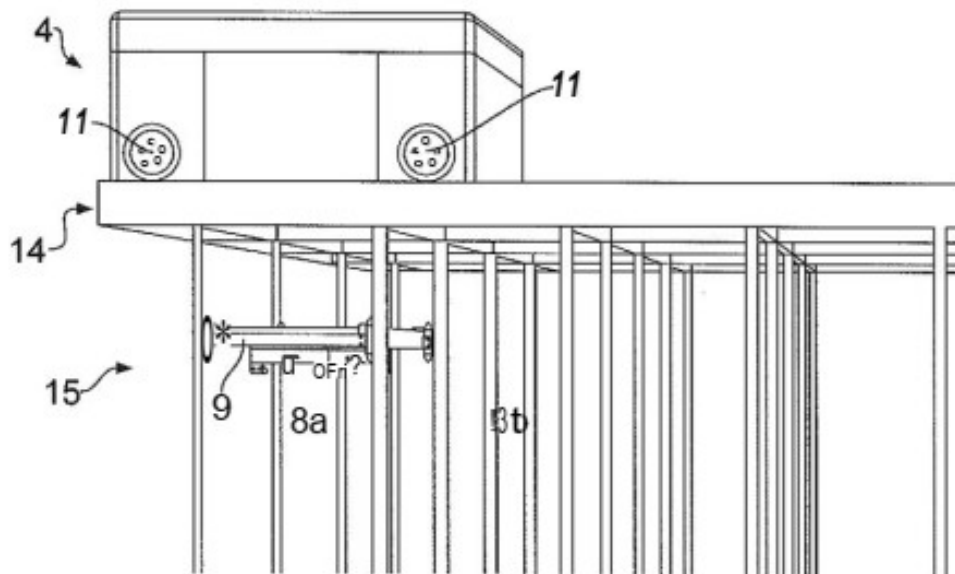

49. Figure 9 illustrates how the side parts of the body influence the freedom of movement of the robots. The robots may be positioned above any storage column unoccupied by another robot. Any two robots may be located adjacent to one another in the X direction as it is shown in figure 9, but must be separated by at least one column in the Y direction to accommodate the side parts:

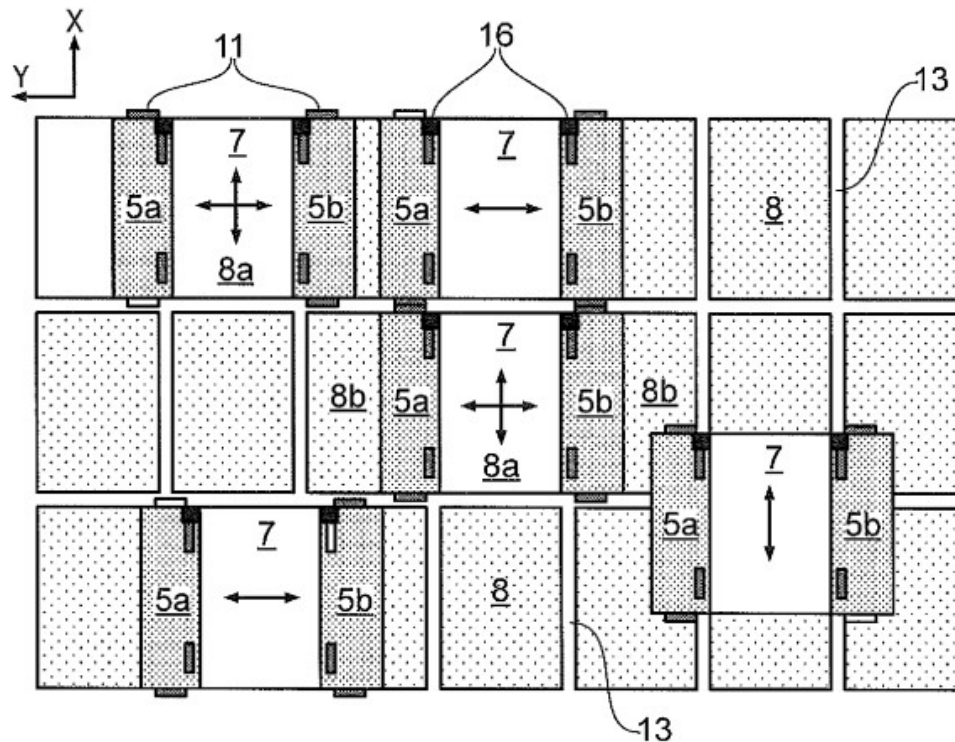

50. Paragraph [0010] of the description explains that the invention claimed is not just the robot, but the system as a whole:

“The present invention also concerns a storage system which comprises a remotely operated vehicle in accordance with the above mentioned features, a vehicle support comprising a plurality of supporting rails forming a two dimensional matrix of guiding meshes, wherein the vehicle support is configured to guide the movements of the vehicle in the first direction (X) and the second direction (Y) during use, a bin storing structure or grid supporting the vehicle support comprising a plurality of storage columns, wherein each of the storage columns is arranged to accommodate a vertical stack of storage bins and wherein the main part of the bin storing structure coincides with positions on the vehicle support where the supporting rails are crossing, and a bin lift device arranged to convey a vehicle delivered storage bin in a direction perpendicular to the lateral plane of the vehicle support between the vehicle support and a delivery station.”

51. Paragraph [0012] explains the advantages conferred by the central cavity:

“The central arrangement of the cavity in the vehicle body relative to the second direction (Y) effectively remove the undesired torque, thereby improving the stability of the robot or vehicle. This arrangement also results in a lifting and transporting process having a weight distribution with a high degree of symmetry. Furthermore, the novel design allows the same vehicle to be used for lifting and transporting storage bins of heights significantly less than the cavity height (i.e. the height extending from the suspension points of the lifting device and to the lower edge of

the vehicle) since the framework / body surrounding at least part of the bin receiving cavity effectively hinders any undesired bin reeling/wobbling. The presence of the cavity surrounding body also allows maintaining full or nearly full lifting speed almost all the way to its end position within the cavity, as well as initiation of stable bin transportations towards the delivery station prior to a fully completed bin lifting from a storage column. The protective body around the cavity also gives the possibility of starting a descent of the lifting device event prior to the time the vehicle has come to a final halt above the storage column in question. A significantly higher stability and time efficiency is thus achieved.”

THE CLAIMS

52. AutoStore asserts the independent validity of two claims, set out here without the reference numbers. The first is claim 1 of EP 794:

“1. Remotely operated vehicle for picking up storage bins from a storage system, comprising a vehicle body comprising a first section for storing vehicle driving means and a second section for receiving any storage bin stored in a storage column within the storage system, a vehicle lifting device at least indirectly connected to the vehicle body for lifting the storage bin into the second section, a first set of vehicle rolling means connected to the vehicle body allowing movement of the vehicle along a first direction (X) within the storage system during use and a second set of vehicle rolling means connected to the vehicle body allowing movement of the vehicle along a second direction (Y) in the storage system during use, the second direction (Y) being perpendicular to the first direction (X),

characterized in that

the second section comprising a centrally arranged cavity within the vehicle body, the cavity having at least one bin receiving opening facing towards the storage columns during use, and at least one of the sets of vehicle rolling means is arranged fully within the vehicle body.”

53. The second is claim 1 of EP 027 which in all material respects is the same as claim 11 of EP 794. The latter is said by AutoStore to be independently valid over claim 1 of EP 794, but its validity over the prior art is accepted to stand or fall with claim 1 of EP 027. This is claim 1 of EP 027:

“1. A storage system comprising

- a remotely operated vehicle,
- a vehicle support comprising a plurality of supporting rails forming a two dimensional matrix of guiding meshes, the vehicle support being configured to guide the movements of the remotely operated vehicle in a first direction (X) and a second direction (Y) during use,

- a bin storing structure supporting the vehicle support, the structure comprising a plurality of storage columns, wherein each storage column is arranged to accommodate a vertical stack of storage bins, and the main part of the bin storing structure coincides with positions on the vehicle support where the supporting rails are crossing,
- a bin lift device arranged to convey a vehicle delivered storage bin in a direction perpendicular to the lateral plane of the vehicle support between the vehicle support and a delivery station,

characterised in that

the remotely operated vehicle comprises a vehicle body comprising a first section for storing vehicle driving means and a second section for receiving any storage bin stored in a storage column within the storage system, the second section comprising a centrally arranged cavity within the vehicle body, the cavity having at least one bin receiving opening facing towards the storage columns during use,

a vehicle lifting device at least indirectly connected to the vehicle body for lifting the storage bin into the second section,

a first set of vehicle rolling means connected to the vehicle body allowing movement of the vehicle along the first direction (X) within the storage system during use and a second set of vehicle rolling means connected to the vehicle body allowing movement of the vehicle along the second direction (Y) in the storage system during use, the second direction (Y) being perpendicular to the first direction (X), at least one of the sets of vehicle rolling means being arranged fully within the vehicle body.”

CONSTRUCTION

Vehicle Body

54. Neither side suggested that “vehicle body” is a term of art, so the court is not much assisted by expert evidence as to its meaning. The specification of EP 794 tells the reader what the term means in paragraph [0002]:

“The inventive vehicle or robot comprises a vehicle body, which vehicle body further comprises a first section for storing vehicle driving means and a second section for receiving any storage bin stored in a storage column within the storage system, a vehicle lifting device which is at least indirectly connected to the vehicle body ... , a first set of vehicle rolling means connected to the vehicle body ... and a second set of vehicle rolling means connected to the vehicle body ...”

55. The specification states that the vehicle body “comprises” the two sections described. Conventional use of “comprises” in a patent specification would allow for the possibility of the vehicle body consisting of something more.
56. Beginning with the vehicle lifting device and the wheels, these are stated to be connected to the vehicle body. AutoStore submitted that if something is connected to the vehicle body it could, depending on context, become part of the vehicle body. Possibly, but not in this instance. That would not be the usual interpretation of “connected to” as a matter of ordinary English and there is nothing in the specification to suggest that an unusual meaning is intended. I think that the reader would infer that neither the lifting device nor the two sets of rolling means is part of the vehicle body.
57. The other candidate for being part of the vehicle body is the outer casing when present. AutoStore directed my attention to the reference number 4, which is used throughout the specification to denote the vehicle body. In figures 3 and 8, shown above, the number points vaguely towards the two sections, although could be taken to point to the whole thing. In figure 2 it points more plainly just to the two sections. In any case, reference numerals are not to be used in the construction of a claim. In an instance of construction having some similarity with the present one, the Court of Appeal said this in *Jarden Consumer Solutions (Europe) Ltd v SEB SA* [2014] EWCA Civ 1629:

“[33] The judge was, therefore, in my judgment, allowing the numerals themselves to influence the construction of the claim in violation of Jacob L.J.'s primary injunction in [17] of [*Virgin Atlantic Airways Ltd v Premium Aircraft Interiors UK Ltd* [2009] EWCA Civ 1062]. This was not a use of numerals simply to identify the parts of the patented device, or, to use Jacob L.J.'s analogy, to enable the reader to get the map the right way up. It was the use of numerals to direct the skilled reader to which parts of the patented device were to be read in the claims as being included when a particular term was used. Whilst, as the judge said, the point was not used to ‘limit’ the claims in direct violation of r.43(7), it was used to construe the claims and, in particular, to give an extended meaning to the term ‘main body’ so as to include the lid, which increased the scope of the patentee's protection. That was in my judgment impermissible.”

58. Reference numeral 4 does not feature in figure 5, which shows the robot with an “enclosing cover”, although the figure is described in this way:
- “Fig. 5 gives a perspective view of a robot assembly where the body 4 is completely covered by an enclosing cover 73 comprising handles 74 and transmission means/control panel 75. The design of the enclosing cover 73 is adapted to the particular shape given by the body 4 and the protruding wheels 10.”
59. This description clearly implies that an enclosing cover, or outer casing, is not part of the vehicle body.

60. Ocado submitted:

“ ... ‘vehicle body’ means a structural chassis (or ‘framework’) to which the other components of the vehicle are at least indirectly connected.”

61. Possibly alighting on Ocado’s word “chassis”, which appears nowhere in the claims, and probably because of the example of a Formula 1 car introduced by Ocado in its written opening skeleton, AutoStore put forward an extended argument using analogies with London buses and Formula 1 cars. In cross-examination Professor Limebeer reflected on his experience in the automotive industry and types of chassis found in that industry, drawing his own parallels with buses and racing cars. I did not find that any of this advanced the issue because I do not believe that similar parallels would occur to the skilled person considering this simple point when reading the specification.

62. In my view the “vehicle body” is what paragraph [0002] says it is: the two sections referred to in that paragraph and elsewhere, no more than that. It does not include the lifting device, the wheels or the outer casing. This is the vehicle body of the robot and therefore the two sections are defined by structural elements of the robot.

Vehicle driving means

63. The specification gives no guidance as to what is encompassed by the term “vehicle driving means” beyond such means being stored in the first section of the vehicle body. There was expert evidence on this from both sides but no suggestion that it is a term of art.

64. AutoStore’s expert, Professor Limebeer, said this in paragraph 141 of his first report in the course of evidence about all of Ocado’s production robots, referred to in the evidence as “Production Bots”:

“The driving means are in-wheel motors, which by their very nature must be situated within the wheel they drive.”

65. Two points are made here: (a) the driving means are motors and (b) in Ocado’s robots they are within the wheel they drive. This was Professor Gerada’s unchallenged evidence for Ocado in his second report:

“54. ... the Electrical and Electronic Engineer would understand the term ‘motor’ in its technical sense as referring to the electromagnetic components which convert electrical energy to mechanical energy. Accordingly, the term ‘motor’ would not include the various types of electronics / control circuitry which are used to power and control it – although the way in which such electronics are operated may affect the way in which the motor itself is classified.”

66. Professor Limebeer did not disagree with this in his written evidence. He said that the electronics may be physically close to or alternatively remote from the motor. But during his cross-examination Professor Limebeer modified his

evidence to say that the motor *includes* power electronics (sometimes called the “motor drives”):

“A. I would say in the case of brushless AC and brushless DC motors, because of the role that they are playing in the operation of the motors, when we talk about a motor in that class, we have to include the power electronics. In the case of a brushless DC motor, the power electronics plays the role of the commutator.

Q. So far as what you say in paragraph 141 is concerned ----

A. I am going back there. What I am saying in the context of 141, we have to be careful that not the entire motor is within the wheels.

Q. That is not a point you make in paragraph 141, is it, at all?

A. It is not made at paragraph 141 ----

Q. Have you ever made this point.

A. --- but I am making it now.”

67. This new idea was hinted at in AutoStore’s skeleton argument, but no attempt was made to amend Professor Limebeer’s written evidence in advance of the trial. This strikes me as an unconvincing afterthought. I prefer Professor Gerada’s unchallenged evidence on this.
68. I find that the vehicle driving means is the motor itself, not the electronics powering and controlling the motor. In Ocado’s robots the vehicle driving means is in the hub of the wheels.

First section of the vehicle body for storing vehicle driving means

69. AutoStore argued that the first section of the vehicle body consists of no more than a volume or volumes which can be used to store the vehicle driving means, i.e. one or more empty spaces.
70. Claim 1 of EP 794 requires “a vehicle body comprising a first section for storing vehicle driving means and a second section for receiving any storage bin”. If the first section is nothing more than a volume, it might be supposed that both sections are volumes, the second being a gap which accommodates the bin. This is AutoStore’s argument.
71. It stretches the understanding of “vehicle body” to suppose that it is just two or more empty spaces and I have found that it is not. Also, the spaces cannot be limitless and so must be defined, necessarily by structural elements. Such structural elements are not separately identified in the description or drawings, so it seems likely that they form part of the first and second sections.

72. The first section consists of structural elements which define the space in which the vehicle driving means are located plus the space itself (though not the driving means).
73. AutoStore submitted that the volume which makes up the first section need not be defined by structural elements which entirely surround the spaces in question. Fewer than six walls may do. This I accept in principle. Five walls and one side open is likely to be sufficient to define a space. Otherwise, it is a question of fact and degree.
74. AutoStore's third point was that having the vehicle driving means stored in the first section does not preclude the location of anything else in that section. I agree.

Vehicle rolling means

75. The description states:
- “At least one, and most preferably both, set(s) of vehicle rolling means may comprise at least four wheels. Other embodiments such as the use [of] two perpendicular oriented caterpillar belts may be envisaged.”
76. Assuming wheels are used, there are two sets, each with two wheels. Ocado submitted that “rolling means” encompasses “all those load-bearing, rotating components that allow the vehicle to move”. This makes some sense and neither side contended that a component such as a decorative removable hub cap would be part of the rolling means. However, it is only possible to arrive at a proper understanding of the term having considered the position of the rolling means relative to the vehicle body, which I discuss next.

At least one of the sets of the vehicle rolling means is fully within the vehicle body

77. I have found that the vehicle body consists of the structural elements which define the space for the vehicle driving means and the cavity for receiving the storage bin. Taking the words “fully within the vehicle body” at face value, one set of rolling means must be positioned so that no part of it is located exterior to the vehicle body.
78. However, “fully within” must be construed purposively. Paragraph [0012] of the specification addresses the advantages of having one set of wheels fully within the body. For convenience I have added numbers to mark the four advantages:

“By arranging at least one set of vehicle rolling means fully within the vehicle or robot body [1] additional stability is obtained during the lifting process since the rolling means is situated closer to the storage bin to be lifted. Of the same reason this arrangement [2] reduces the total load on the lifting device. Furthermore, the arrangement is [3] more space efficient relative to the prior art robot illustrated in figure 2 since the roller [sic] means does not give any additional extensions in at least one of the two robots moving

directions (X and Y). [4] Production of smaller sized robots/vehicles is also rendered possible.”

79. The third reason was the one given particular attention by the experts dealing with this (Professor Limebeer for AutoStore and Professor Fottner for Ocado). They understood the notion of there being “additional extensions” to mean the wheels projecting beyond the exterior of the vehicle body. It was common ground between them why having the wheels within the vehicle body leads to greater space efficiency. Professor Limebeer illustrated his reasoning using the diagram below. (A) represents a central cavity robot with exterior mounted wheels; arrangement (B) has the set of wheels within the vehicle body:

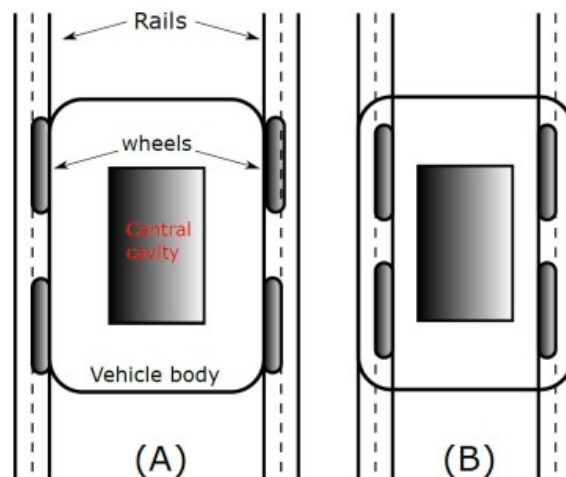

80. The rails are supported by storage columns. If the rails are closer together as in (B), the storage columns are narrower and more of them will fit into a given size of warehouse. The bins, slightly smaller than the central cavity, will be more densely stacked, thus improving space efficiency, or as the experts described it, volumetric efficiency. In arrangement (B), the wheels would be within the vehicle body, in the side parts but not in the central cavity.
81. Another alternative (C) was illustrated by Professor Limebeer. If the wheels are moved further inwards to abut the central cavity, bringing the rails further inwards, there is a greater density of storage columns. In this arrangement, the storage columns are not significantly wider than the bins, allowing the densest packing of bins within the warehouse:

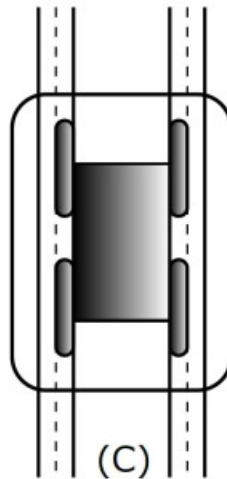

82. Ocado criticised Professor Limebeer’s diagrams. Diagram (A) does not show the prior art, diagram (C) is different from the arrangement in figure 3 of EP 794 and if all or any of the arrangements were to be implemented exactly as shown they may (or may not) give rise to technical difficulties. To my mind, this is beside the point. They are helpful in explaining the broad principle.
83. Professor Fottner put it this way: storage density (or volumetric efficiency) is solely governed by the distance between the wheels (of the relevant set) and the proximate edge of the storage bin. The closer that distance is to zero, the greater the storage density. It does not matter whether the wheels are located within the vehicle body, as in Professor Limebeer’s diagram (C) or in the central cavity as in figure 3 of EP 794.
84. Ocado’s argument on this point of construction was that maximising volumetric efficiency by using the arrangement in figure 3 of EP 794 is what the skilled person would have understood from the words “*fully* within the vehicle”.
85. AutoStore submitted that the invention does not necessitate the *maximising* of volumetric efficiency, that is not what is claimed for the invention in paragraphs [0001] and [0012]. Any arrangement leading to an improvement is enough; the claim covers the positioning of the wheels anywhere from just inside the robot body to immediately adjacent the bin. Professor Limebeer said that this followed from the inventive concept of EP 794, which he defined this way:
- “... the Skilled Engineer would consider the technical advantage [of the invention] to reside in an improvement in volumetric efficiency in the context of a given robot with a central cavity.”
86. In their closing argument Ocado developed a further point, focussing on the relationship between the bin and the central cavity in the robot. Professor Limebeer had explained in cross-examination that the bins fit fairly snugly into the storage columns to minimise undesirable lateral movement as the bin is pulled up; each bin then moves into the bin cavity of the robot which

accommodates the bin equally snugly. He said that this snug arrangement was important. Ocado marked up figure 3 of EP 794 to highlight features to which they gave the friendly name “nubbins” (circled in red). These are corner projections to secure the snug fit of the bin:

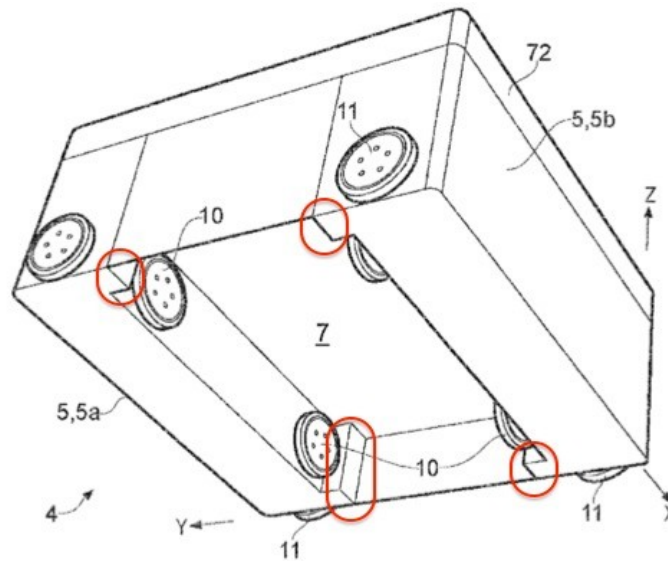

87. For the arrangement shown in figure 3 to work, the highlighted corner projections have to be immediately above the pillars of the storage columns with the robot cavity exactly matching the position of the top of the column.
88. It follows, Ocado’s argument continued, that there are only two places that the “X” wheels marked 10 can go. Either where they are shown in figure 3 or outside the side parts 5, in which case the only rails available would be one grid square away on each side. Ocado referred to the cross-examination of Professor Limebeer on this, who confirmed that these were the two alternatives and said that the second would require additional extensions from the side pieces and that it would not be space efficient. He described this proposed alternative as “going into bizarre-land”.
89. Ocado concluded from this part of Professor Limebeer’s evidence that the skilled person would be bound to select the first alternative and therefore would understand that this is what the patent means by the vehicle rolling means being fully within the vehicle body.
90. Ocado’s argument ignored a key qualification given by Professor Limebeer in the passage of his cross-examination relied on. He went along with it only

“...if this mesh has been fixed in terms of geometry...”

91. I do not accept that implied premise of the argument, that the skilled person would understand that the invention must be practised on an existing, fixed structure of columns in a fixed grid. As I have noted, paragraph [0010] of the description explains that the invention claimed is not just the robot, but the system as a whole. To achieve greater storage density using an existing grid would require an increase in one dimension of the bins so that it is just less than

the width between the columns. The experts did not appear to believe that this was the approach underlying the invention as explained in EP 794 and nor do I. The experts seem to have taken as read the desirability of keeping standard bins of the same fixed dimensions and – this they both said expressly – improving volumetric efficiency by changing the dimensions of the storage columns and thus the spacing of the rails.

92. In their closing submissions Ocado said this (at [48]):

“We know that the Fig 2 robot (the cantilever robot in the AutoStore Redline system) was close to 100% space efficient because the columns of bins in storage were only separated by the width of the rails and thus extend as far as the pillars in each corner.”

93. No source is given for this assertion, although earlier in their closing submissions they said:

“41. The storage system of the 794 Patent is explicitly founded on the conventional and well-known AutoStore ‘Red Line’ system in which, as explained by Mr Knights, stacks of bins are positioned in columns, the pillars which make up those columns acting as guides as the bins were pulled up the columns. The bins occupy the whole of the space in the columns, to maximise storage capacity. The pillars act as guides to stop the bins swinging about when being lifted or lowered. See Knights First Report §77, first sentence. The columns are matched by a grid of rails sitting on top of the storage system, with the pillars supporting the intersections between the rails. This is all depicted in Fig 1, and precisely the same arrangement of pillars and grid are shown in Figs 6, 7 and 8 as the underlying storage system of the invention. The whole point of this system is to maximise storage efficiency, at which it is very effective.”

94. I quote here the first sentence in paragraph 77 of Mr Knight’s first report, in which he discusses AutoStore’s Red Line system:

“77. The columns are used to support the rails on which the robots move and they are also used to guide the storage containers as they are stacked within the storage block.”

95. Mr Knight did not say that the bins in the Red Line system occupy the whole of the space in the columns. Apparently the columns guided the bins, but this need mean no more than that they prevented excessive swinging from side to side.

96. This is figure 1 of EP 794:

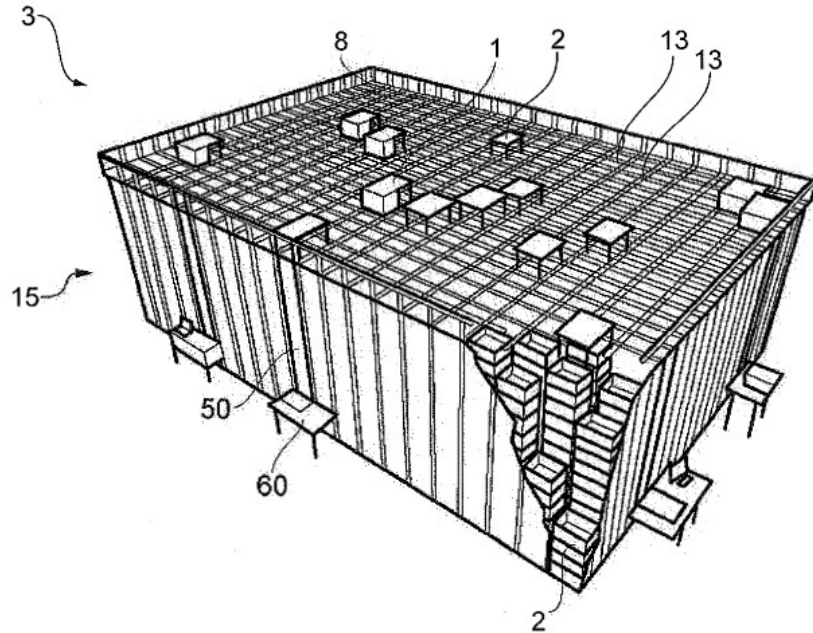

FIG. 1 (Prior Art)

97. Figure 1 is too diagrammatic to infer from it that in the AutoStore Red Line system the bins were practically a perfect fit for columns.
98. If they were, it would confound EP 794's promise of the invention claimed being "more space efficient relative to the prior art robot illustrated in figure 2". It would also make a nonsense of the evidence of Professors Limebeer and Fottner referred to earlier about having the wheels within the vehicle body leading to greater space efficiency. I must be guided by this evidence because it requires technical expertise to appreciate why having the wheels fully within the vehicle body would lead to the promised space efficiency.
99. Ocado's assertion is contrary to what the experts said. This was the evidence of Ocado's expert, Professor Fottner, in his first report (the "Chubby Bot" is a robot according to the invention of EP 794):

"125. Powell Gilbert has explained to me that the Claimant has stated at paragraph 6 of its Amended Statement of Case on Infringement that the use of a centrally arranged cavity within the vehicle body together with at least one set of vehicle rolling means arranged fully within the vehicle body confers the following technical advantages:

'The result of this is a bot that couples the advantages gained from having a centrally arranged cavity with efficiency as to the spacing between the elements of the vehicle support (i.e. the rails upon which the bot wheels run), in at least one of the X and Y directions. This increases the proportion of space in the storage facility that can be used for storage.'

126. It is correct that the high degree of storage density in the system described in the Chubby Bot Patents is achieved by the spacing between

the elements of the vehicle support. In particular, the rails are placed close to the storage bins in the storage column so that the amount of free space around the storage bins is minimised.”

100. Professor Fottner’s second report included this:

“22. The rationale for the design of the robots described in EP 794 is different. By placing at least one set of wheels fully within the vehicle body, thereby minimising as far as possible any wasted space around the storage bin in the cell (by making distance A as close as possible to 0), the highest possible storage density is achieved.”

101. Leaving to one side Professor Fottner’s implied view on the construction of “wheels fully within the vehicle body”, I understand him to have been saying that EP 794 both promises and delivers improved storage density.

102. Professor Limebeer’s evidence was similar in his first report:

“100. The patent attributes this space efficiency to the fact that “*the roller [sic] means does not give any additional extensions in at least one of the two ... directions (X and Y).*” The Skilled Engineer would understand this to be referring to the fact that at least one of the two sets of wheels (rolling sets), i.e. one or both sets of wheels, would not be external to the robot’s body. This would have two geometrical benefits. First, the rail spacing can be reduced, increasing the volumetric efficiency of the system by allowing storage columns to be placed closer together.” [The second stated benefit is a smaller size of robot.]

103. There was some cross-examination of Professor Limebeer on this, which I did not find conclusive.

104. Overall, the experts’ understanding was that volumetric efficiency is improved by the invention of EP 794 because rail spacing is in play. I cannot accept Ocado’s assertion that no improvement over the prior art was possible because the prior art was close to 100% efficient.

105. Related to this, Ocado made this further point in their closing submissions:

“56. Professor Limebeer’s position was that the claim covered a range of possible positions for the X wheels, from ‘just inside’ the outer edge of the side pieces of the robot to the final position adjacent to the cavity which we say is ‘fully within’.

57. He was candid in his Reports that each of these would be less storage efficient than the ‘fully within’ position as construed by Ocado, and therefore of course worse in terms of storage efficiency than the prior art robot shown in Fig 2, because the position of the rails would have to be moved outwards whilst the bins would remain the same size.”

106. I think it is worth noting what Professor Limebeer actually said (first report):

“104. Placing the wheels 10 at the inside of the cavity, on the interior walls of the cavity, produces optimum volumetric efficiency of the cubic storage system. However, placing the wheels at any distance within the side pods (marked 5,5a and 5,5b) achieves an improved volumetric efficiency as compared with exterior wheels as in the prior art cantilever robots.”

107. In other words, positioning the wheels anywhere in the side pods would improve volumetric efficiency.
108. I have the impression that by the time of closing submissions Ocado had developed an assumed premise that the prior art was near enough 100% volumetrically efficient. Placing the relevant wheels adjacent to the bin offered 100% efficiency and this matched the prior art. Placing them any greater distance from the bin must reduce efficiency relative to the prior art. This reasoning seems to me to lack any evidential basis and is contrary to what the experts said. The unsupported premise is wrong.
109. In summary: rail spacing can be varied to any extent down to separating the rails by a distance just wider than the standard width of the bins. The closer the rail separation is to the latter, the greater the bin density and volumetric efficiency in the warehouse; a reduction in rail spacing to any degree relative to the prior art will lead to some increase in volumetric efficiency.
110. In my view AutoStore was right to say that the skilled person would not interpret the invention claimed as being limited to achieving the maximum volumetric efficiency. Any positioning of the wheels which achieves an improvement in bin density compared to the prior art is covered by the invention.
111. In principle, this might include moving the wheels so that they are only partially within the vehicle body. Whether or not that is realistically the case, the patentee has chosen to limit the invention to arrangements wherein the wheels are fully within the vehicle body. In my view that should be given its ordinary meaning which, as I said at the start of this section of the judgment, is that no part of the rolling means is located exterior to the vehicle body.
112. Two further points arose under this head:
- (1) What counts as a part of the rolling means when assessing whether the whole is fully within the vehicle body?
 - (2) What is the outermost extent of the vehicle body which the rolling means must be fully within?
113. As to the first, the advantage of better volumetric efficiency promised by the invention depends on reduced rail separation. The only parts of the relevant set of wheels that matter are those in contact with the rails, the traction surfaces; they must be moved inwards and the words of the claim require their position to be fully within the vehicle body. The invention is not concerned with the position of any other part of the wheels or, for instance, with the possible size

of wheel hubs which may extend outwards. The rolling means are the traction surfaces of the wheels.

114. As to the second, I have found that the vehicle body consists of structural elements which define the space for containing the vehicle driving means and the cavity for receiving the storage bin. The wheels must not be positioned so that any part in contact with the rails extends outside those structural elements.
115. Mr Purvis drew homely analogies: a person standing on a veranda is not fully within the house even though the veranda is part of the house; eyes are not fully within the skull even though the eye cavities are part of the skull. These did not really advance the argument. EP 794 and the robots alleged to infringe have vehicle bodies with substantially straight sides. Subject to the points of construction, it is not difficult to take a view as to whether the wheels are fully within the vehicle body. I need not worry about skulls and verandas.

Bin lift device

116. The storage system of claim 11 of EP 794 includes:
- “... a bin lift device arranged to convey a vehicle delivered storage bin in a direction perpendicular to the lateral plane of the vehicle support between the vehicle support and a delivery station.”
117. The only illustration of the bin lift device is in figure 1 (see above) which shows AutoStore’s prior art Red Line system.
118. The point in issue was whether, as Ocado argued, the device must be distinct from the robot or whether, as AutoStore submitted, it may either be distinct or alternatively may form part of the robot. In the latter alternative the robot would use an empty column in the storage system to shuttle bins between the delivery station at the base of the column and the rails at the top.
119. The bin lift device is only mentioned using that term in the description of the Red Line prior art in paragraph [0001]:
- “The storage system includes a plurality of such robots and a dedicated bin lift device, the latter received to receive a storage bin from the robot at the top level of the bin storing grid and to convey the storage bin down in a vertical direction to a delivery station.”
120. The words “vehicle-delivered” in the claim and “dedicated bin lift device” and “receive a storage bin from the robot” in this passage of the description could be taken to imply that the robot delivers bins to a distinct bin lift device, but they leave some ambiguity.
121. The experts agreed that the skilled person would believe that the bin lift device was the same as that in the Red Line system. The parties’ Statement of Agreed Common General Knowledge included this in a section setting out the CGK as regards AutoStore’s Red Line:

“53. The robots retrieve containers from within the grid structure and deliver them to the workstations located around the edge of the grid for the human operator to either pack or pick product as required. The container would then be taken back to a storage location in the grid structure by the robots.”

122. Although not spelt out, this statement that robots deliver to the workstations, rather than delivering to another device which in turn passes the bins on to the workstations, indicates that moving the bins to and from the workstation was done by the robot.

123. Professor Fottner’s evidence in cross-examination was that it was part of the common general knowledge that the Redline system was marketed with alternative means of moving bins to and from the delivery station:

“A. In the AutoStore system, it was known that there were different ways. The first one, there was even a port with a magazine, which is clearly a conveyer working in that. It is shown in the brochure, and it was clearly known that there are different ways to handle that. In some, it was more critical to save the time, there you use the bin lift device; in some you wanted to save the cost, there you had an empty column as a solution, but that was just the CGK, that is not what I learned from the patent.”

124. A brochure advertising AutoStore’s Red Line system was in evidence. It has a diagram which appears to show a magazine which does the transporting down to the delivery station. But the brochure says expressly: “There are two different solutions to the port, with or without magazine”, which confirms Professor Fottner’s evidence on this.

125. AutoStore submitted that figure 1 of EP 794 illustrated bins being moved to and from the delivery station by a robot, as opposed to a separate device, down an empty column. As I have said, figure 1 is diagrammatic. It would convey only limited information. The reference number 50 points to an empty column but the device at the top of the column is not specified.

126. Given that the parties were agreed that the skilled person would understand that the arrangement for bin lifting to and from the work station in EP 794 was the same as in AutoStore’s Red Line system and given the evidence that the arrangement took two alternative forms, I find that the bin lifting in claim 11 of EP 794 can either be done by a robot or alternatively by a separate bin lift device. Possibly, figure 1 may be taken to imply that in both cases the device is not just the apparatus that does the lifting but also the column up and down which the bins are transported. I am not sure that it matters.

127. In both cases the words of the claim require that the bin lift conveys a “vehicle-delivered” storage bin. The vehicle is a robot. If the lifting and lowering is done by the robot, the robot doubles up as the vehicle delivering the storage bin to and from the top of the column and as the bin lift device.

Storage bin

128. The description identifies:

“... a plurality of storage columns, wherein each of the storage columns is arranged to accommodate a vertical stack of storage bins ...”

129. Storage bins are what they sound like: bins used to contain items stored in the warehouse. They must be robust enough to be stacked on top of each other within a storage column. They may contain items or be empty.

INFRINGEMENT

The law

130. There was no dispute as to the law. Infringement is to be considered in the usual two stages of whether an alleged infringing robot or storage system falls within any relevant claim on a normal, purposive construction; if not, whether it is an equivalent of the claimed invention, see *Actavis UK Ltd v Eli Lilly & Co* [2017] UKSC 48 and *Icescape Ltd v Ice-World International BV* [2018] EWCA Civ 2219.

131. These are the three questions set out by Lord Neuberger in *Actavis UK Ltd v Eli Lilly & Co* [2017] UKSC 48, at [66], to be answered when assessing equivalence:

“(i) Notwithstanding that it is not within the literal meaning of the relevant claim(s) of the patent, does the variant achieve substantially the same result in substantially the same way as the invention, i.e. the inventive concept revealed by the patent?”

(ii) Would it be obvious to the person skilled in the art, reading the patent at the priority date, but knowing that the variant achieves substantially the same result as the invention, that it does so in substantially the same way as the invention?

(iii) Would such a reader of the patent have concluded that the patentee nonetheless intended that strict compliance with the literal meaning of the relevant claim(s) of the patent was an essential requirement of the invention?”

132. Both sides referred to a point I made in *Kwikbolt Ltd v Airbus Operations Ltd* [2021] EWHC 732:

“[99] The doctrine of equivalents as explained in *Actavis* requires the variant to be specified. This will be the invention of one of the claims of the patent in suit with one or more integers missing or modified. In the simplest case one integer of the claim is missing in the variant – this will be the integer in issue. The parties will know what that integer is and each may tend to tailor its inventive concept accordingly. ...”

...

[103] ... a correct assessment of the inventive concept cannot be achieved with the variant in mind. The correct identification of the inventive concept must be done through the eyes of the skilled person, who has no notion of what the variant is. The skilled person has only the relevant claim, the specification as a whole and his or her common general knowledge to work with. Only after the inventive concept has been identified does the variant and with it the integer(s) in issue come into play so that the three *Actavis* questions ... may be considered”.

The inventive concept in this case

133. AutoStore’s “summary” of the inventive concept disclosed in EP 794 and EP 027, stated in its closing submissions was:

“A cubic storage system comprising the particular features of its structure (in particular the provision of storage columns arranged to accommodate a vertical stack of storage bins) together with a robot comprising a centrally arranged cavity within the vehicle body together with at least one set of vehicle rolling means arranged fully within the vehicle body. The result of this is a system with advantages we have identified above as being the result of the adoption of the central cavity feature. Overall, the system provided has increased stability of both vehicles and bins enabling increased handling weight and speed both of vehicles and of the raising and lowering operation. In addition (in relation to 027 and 794) the system couples those advantages gained from having a centrally arranged cavity together with efficiency as to the spacing between the elements of the vehicle support (i.e. the rails upon which the bot wheels run), in at least one of the X and Y directions. This increases the overall proportion of space in the storage facility that can be used for storage.”

134. I find this to be unhelpfully diffuse. Ocado’s inventive concept was snappier:

“The placing of the wheels inwards of the body, so that they are adjacent to the cavity, thus maximising storage efficiency in the relevant dimension.”

135. I think that there are two flaws in Ocado’s inventive concept. First, it entirely omits the presence of, and advantages conferred by the central cavity. Secondly, for reasons I give in the main section of this judgment, I do not accept that the inventive concept requires the maximising of storage efficiency; improving it to a significant degree is enough.

136. Ocado’s counsel submitted that infringement by equivalence could never work if the advantage conferred by the inventive concept is a continuum – where the more it is used, the greater the advantage. He said that in such an instance there would be no means to draw the line and the third *Actavis* question would inevitably favour the patentee. I fail to see why. An inventive concept may be

exploited efficiently to gain maximum advantage. Alternatively, a defendant may infringe badly in the sense that his product or process exploits the inventive concept, but in a way that confers no benefit. And there may be a range (or continuum) of possibilities in between. The third *Actavis* question is one of interpretation of the patent. Wherever the defendant is on the foregoing range, the court may interpret the patent to infer that strict compliance with one or more integers of the claim was intended by the patentee or may not.

137. I take the view that the inventive concept of claim 1 of EP 794 has two aspects to it. The first is the idea of lifting bins into a cavity located centrally in the robot for subsequent transportation and deposition. This provides greater stability and speed of operation and allows access by any one robot to all available storage columns in the system. The second is the technical insight that having at least one set of vehicle rolling means fully within the robot body results in greater space efficiency of the storage system. Other advantages to the second aspect are identified in the specification of EP 794, namely the reduction in total load and the possibility of smaller robots, but these were given little attention by the experts or counsel and so can be left to one side.
138. The circumstance of the patentee having chosen to frame its invention such that there are two aspects to the inventive concept, and aspects which are not inter-dependent or if so, only tenuously, raises a question. Must both aspects be substantially exploited by the defendant – in the sense that in relation to each of them the defendant has achieved substantially the same result in substantially the same way – for there to be infringement by equivalence? In my view, yes.

Ocado's robots and storage system

139. The Ocado Smart Platform (“OSP”) uses three production robots which are in issue, given model numbers 400.1, 400.02 and 500. I will refer to these collectively as “the Production Bots”.
140. The parties were agreed for reasons which will become apparent that I should also consider infringement in relation to the Production Bots if they were marketed and used without cladding.
141. There are four elements of the OSP grid which are relevant to the issues on infringement. They are the picking stations, the delivery tote machine (“DTM”), the tote-out machine (“TOM”) and the combination-separation machine (“CSM”).
142. Ocado has proposed an amended robot, designated “Modification 4A” and the parties have agreed that I should assess infringement in relation to Modification 4A, subject to AutoStore’s contention that I do not have sufficient information on which to arrive at a conclusion.
143. The foregoing robots and elements of the OSP grid, Modification 4A and what is meant by “cladding” of the Production Bots are discussed in Ocado’s confidential product and process description (“the PPD”). I will explain these various elements of Ocado’s system in more detail below.

144. I will discuss the issues by reference to EP 794. No further issues arose in relation to EP 027.

The infringement issues

145. I begin with the issues arising in relation to infringement on a normal construction of the claims. They are:

- (1) Do either (i) the Production Bots or (ii) the Production Bots without Cladding (as that term is defined in the PPD) comprise a “vehicle body comprising a first section for storing vehicle driving means”?
- (2) Is there “at least one set of wheels arranged fully within the vehicle body” in:
 - (i) the Production Bots;
 - (ii) the Production Bots without Cladding; and
 - (iii) a robot with the “Modification 4A Tyre Assembly”?
- (3) Are the following components, all of which are mechanisms (or proposed mechanisms) in the OSP Hive for getting bins from the top of the OSP Hive down to the bottom or vice versa, “bin lift devices” within the meaning of the claim:
 - (i) Type 1 and Type 2 Picking Stations;
 - (ii) a Tote-out-Machine (“TOM”);
 - (iii) a Delivery-Tote Mechanism (“DTM”);
 - (iv) Type 1 and Type 2 Combination-Separation Mechanisms (“CSMs”).
- (4) Is the bin that is lifted up from the delivery station to the top of the grid by the DTM a “vehicle delivered” storage bin?
- (5) Is the delivery tote that is lowered to the delivery station by the DTM a “storage bin”?

The principal differences between EP 794 and Ocado’s Production Bots

146. The robot of EP 794 was developed from the cantilever arrangement of the prior art. Moving the bin from being held by the overhanging part of the robot to a central cavity led to the vehicle driving means being located in sections either side of the central cavity as shown in this plan diagram:

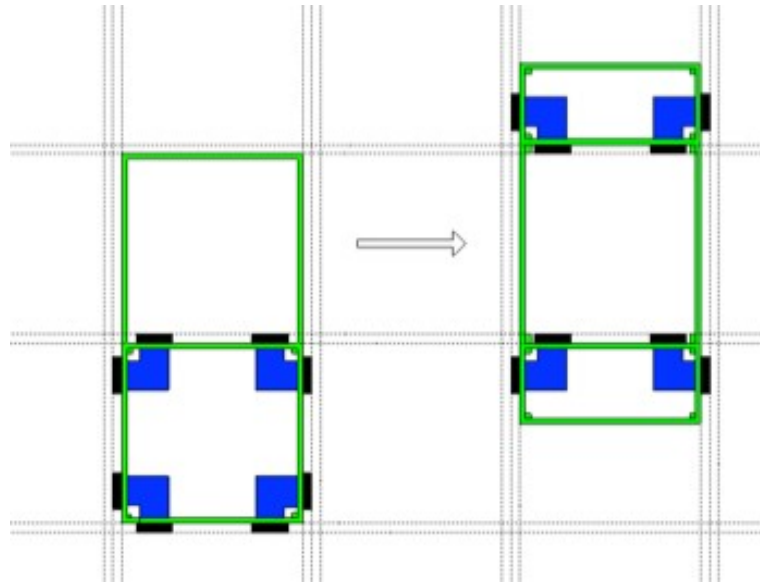

147. As can be seen, the robots of both the prior art and EP 794 can be deployed to adjacent storage columns in one direction but not the other.
148. A feature of Ocado's system is that the robots can work over adjacent storage columns in both directions. Although not shown in the following diagram, instead of double rails in one direction only, there must be double rails in both directions to exploit the possibility of robots being in adjacent columns in both directions. The robots are of a reduced size to match the shape of the columns:

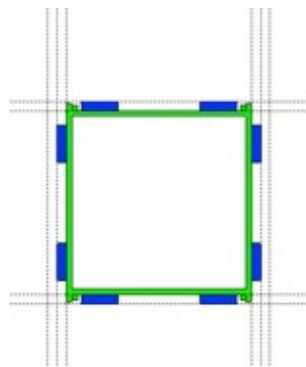

149. The respective spaces for the vehicle driving means in the cantilever robot and the EP 794 robot have both gone. Ocado's solution is to replace the internal driving means with hub motors.

A first section for storing vehicle driving means

150. I have found that the "first section" of claim 1 consists of structural elements which define the space in which the vehicle driving means is located plus the space itself (though not the driving means).
151. The vehicle driving means in Ocado's robots are in the hubs of the wheels. AutoStore argued its case by reference to photographs and diagrams of the 400.02 Bot without cladding. It was common ground that there was nothing in

the structure of the other robots that made any difference; the 400.02 Bot could be taken to represent all of them. One of the photographs shows the positions of the wheels and the boxes which contain their electronic controls:

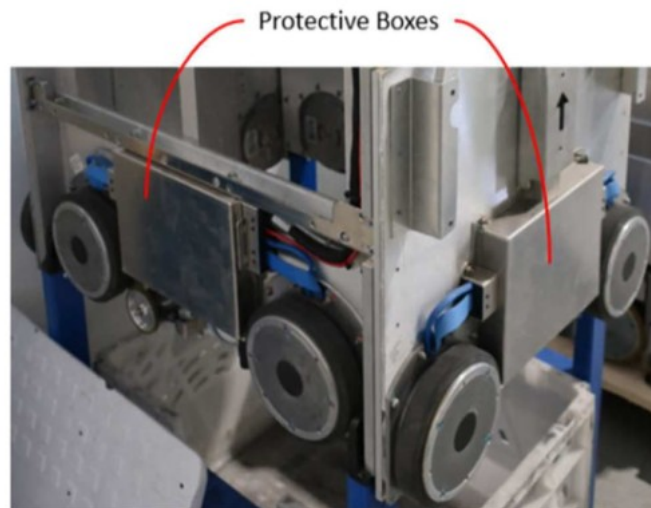

152. Another was a diagram of a 400.02 Bot viewed from below with a red zone marking what AutoStore said was the first section within the meaning of claim 1:

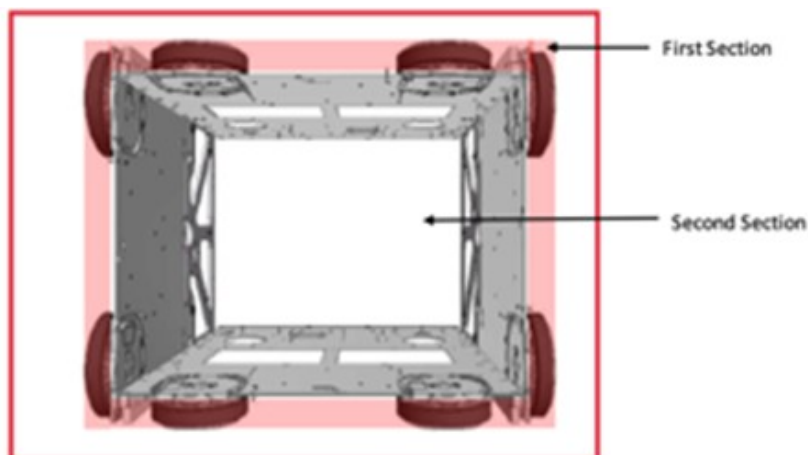

153. In effect, AutoStore's argument was that one notionally draws a perimeter around the outermost parts of the robot; the zone between that notional perimeter and the structural elements of the second section, shaded in red in the diagram above, constitutes the first section.
154. It is possible to see that two of the side surfaces in this diagram have projecting elements, shown extending into what is labelled the first section. AutoStore attached importance to these because they were said to create a recess on two sides within which the wheels on those sides are located.

155. I reject AutoStore’s argument. The relevant integer of the claim requires a first section for storing vehicle driving means, not that there is a space somewhere in which the vehicle driving means are located – which would be practically no limitation at all. The first section must be defined by structural elements. Notwithstanding the projections referred to above, AutoStore’s first section is in my view a structurally undefined space which has been given significance because it contains the wheel hubs. It may not matter, but on two sides of the robot there are not even projections on which AutoStore can rely to complete what it says is the first section. I think that Ocado was right to call the illustrated first section a “virtual volume”.
156. Adding cladding makes no difference. As I have found, the cladding is not part of the vehicle body:

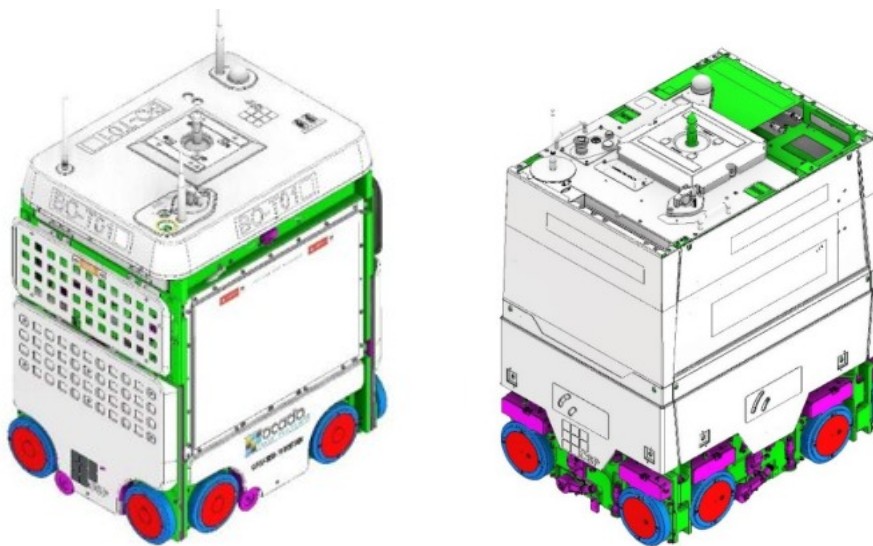

157. AutoStore’s first section is still a structurally undefined space, although little of it remains a space, having been substantially filled in by the cladding. If it were assumed that the cladding is part of the vehicle body, the zones occupied by the wheels are not a space, singular.
158. This integer of the claim is not satisfied by Ocado’s robots with or without cladding; there is no first section for storing vehicle driving means.

One set of vehicle rolling means fully within the vehicle body

159. I have construed this to require that no part of the traction surfaces of one set of wheels may be positioned exterior to the vehicle body, i.e. the structural elements which define the two sections referred to in paragraph [0002] of the description. I have also found that the wheels are not part of the vehicle body since they are described as being attached to the vehicle body.
160. In the Ocado robots all the wheels are attached to the exterior of the structural elements which define the two sections, so all their traction surfaces are exterior to the vehicle body.

161. Further, as discussed in the main part of this judgment, EP 794 explains that arranging at least one set of wheels fully within the vehicle body brings greater space efficiency relative to the cantilever prior art system. This means that it allows rails to be more closely spaced and therefore more closely packed bins in the warehouse. It was not shown by AutoStore that Ocado's OSP system achieves this improvement in space efficiency, which would cast doubt in the mind of the skilled person on there being one set of wheels "fully within the vehicle body" within the meaning contemplated in claim 1.
162. This integer is not satisfied in Ocado's Production Bots, with or without cladding.
163. There was a separate argument based on a view advanced by Ocado that the vehicle driving means, the wheels, include hubs which project exterior even to AutoStore's virtual first section space. AutoStore further developed its side of this argument by reference to the doctrine of equivalents. Given my finding that the skilled person would focus only on the position of the traction surfaces of the wheels, all this falls away.

Mod 4A

164. It is convenient to deal at this point with Ocado's application for a declaration of non-infringement ("DNI") as it relates to EP 794 since its entitlement to the declaration turns on the question whether the robot proposed would have one set of wheels fully within the vehicle body. It was designated "Mod 4A". The design is not yet finalised and AutoStore submitted that it was not possible for the court to grant a DNI in relation to a work in progress of uncertain final form.
165. It will be unusual that a court will be prepared consider the grant of a DNI in relation to a product that is not in a fixed and final state. To do so is liable to lead to a judgment on a hypothetical issue. However, in the present case the DNI sought turns on one feature of the Mod 4A design which is in a fixed and final state. The DNI sought amounts to a point of construction regarding that feature. The point of construction is closely related to issues I have had to resolve anyway, and it may be that to decide the point now will save time and costs in the long run. I will therefore deal with it.
166. The key amendment to Ocado's production robots would be the use of a new type of wheel located partly inside the structural elements of the two sections and partly outside. The proposed relative positions of the wheel and those structural elements, labelled "chassis outline", is shown here (redacted) from beneath the robot:

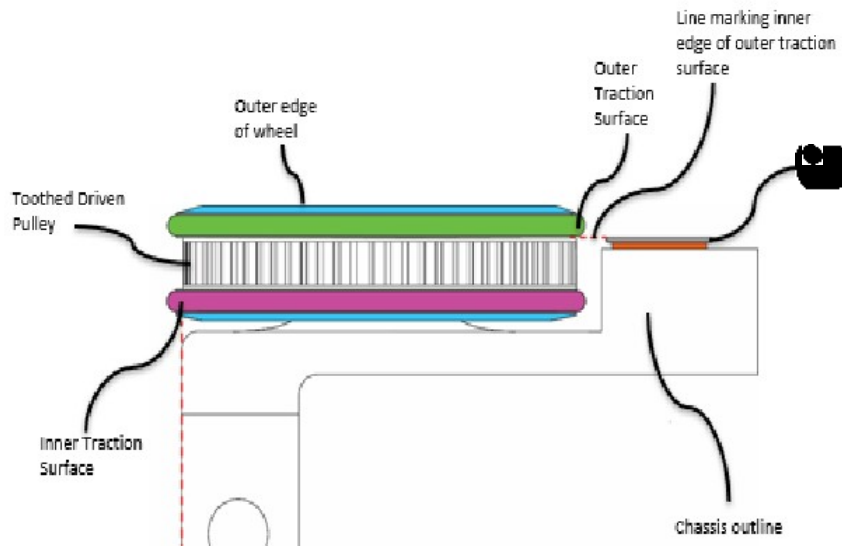

167. This is the proposed drive mechanism (redacted):

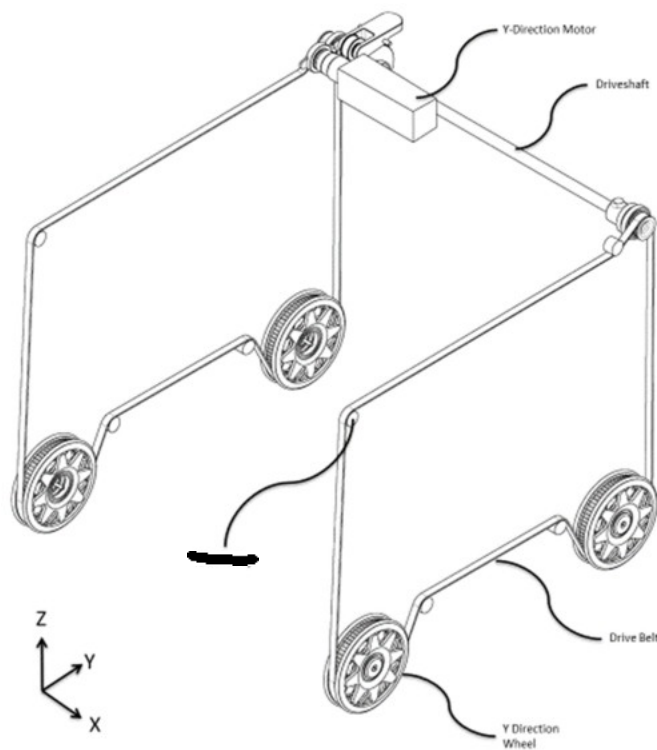

168. Ocado calculated that 50% of the traction surface protrudes beyond the structural elements of the two sections. AutoStore said it was 27.5%. Argument was directed to this aspect of Mod 4A. In effect, Ocado sought a declaration that any robot with partly protruding wheels of this design would not infringe claim 1 of EP 794.

169. AutoStore submitted that this wheel feature could not by itself save a robot from infringing on a normal construction. Alternatively, such a robot would take the

substantial benefit of the inventive concept of EP 794 and its use would therefore infringe under the doctrine of equivalents.

170. On the construction of “vehicle body” as I have found it to be, the wheels of Mod 4A would not be fully within the vehicle body. Assuming that 27.5% protrusion is the correct figure, on a normal and purposive construction of claim 1 of EP 794, it would make no sense to say that those wheels are fully within the vehicle body. Such a robot would not infringe.

An equivalent

171. The variant here, Mod 4A, has the central cavity, so attention was focussed on the wheels and their position relative to the vehicle body. The variation is having part of the traction surfaces of one set of wheels within the vehicle body and part outside.
172. The first *Actavis* question, adapted to the present facts, is whether the Mod 4A robot would achieve substantially the same result in substantially the same way as does the inventive concept. Does moving the wheels partly inside the vehicle body achieve substantially the same result, in the form of improved space efficiency, in substantially the same way?
173. AutoStore said yes, Ocado no. On the evidence, I have no way of telling. AutoStore filed quite a lot of evidence on equivalents in relation to Ocado’s production robots intended to demonstrate improvements in space efficiency. But the improvements were measured against what Professor Limebeer called a “datum point”, a notional robot which looked like this:

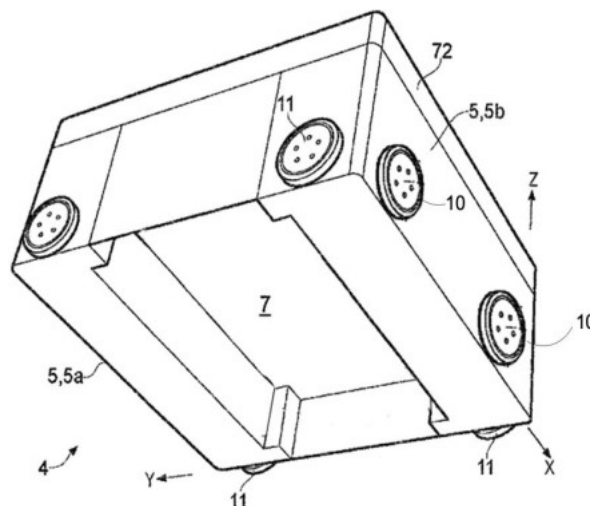

174. So far as I am aware, a robot of this design has never existed. Whether there is improved space efficiency in relation to this datum point is not what matters. The question is whether Mod 4A would give rise to a significant improvement in space efficiency relative to the cantilever prior art. I don’t know. I therefore cannot answer the first question on the evidence available. Nor can I reach a considered answer to the second *Actavis* question.

175. The answer to the third *Actavis* question rests on the correct interpretation of the patent and whether the skilled reader would understand that the patentee's choice of words in the claim and in the specification as a whole was intended to inform the reader of a bright line requirement for performance of the invention – strict compliance. The reader is told, both in the description and the claims, that at least one set of vehicle rolling means must be arranged *fully* within the vehicle body. The alternative of saying “arranged within the body” was not adopted. In my view, the words used are strong enough for the reader of the patent to take this to be a bright line requirement. Mod 4A falls outside claim 1 of EP 794. Ocado is entitled to a DNI.

Bin Lift Devices

176. There is an issue between the parties as to whether all or any of four components of the OSP system are bin lift devices within the meaning of claim 11 of EP 794 on a normal construction.

Pick stations

177. Ocado operate two pick stations, designated Types 1 and 2. There is no relevant distinction for the purpose of this issue.
178. The bins in the Ocado system are called “totes”. “Hive totes”, also called “inventory totes”, are used to store inventory. “Delivery totes” are used to store customer orders. Delivery totes are slightly smaller than inventory totes. A delivery tote may sit inside an inventory tote, creating what is called a “nested tote”.
179. The robots lower totes down an empty column known as the “arrival column” to an arrival position. Horizontal conveyors move the totes from the arrival position to a pick position where a human picker selects required products from inventory totes and places them into a nested tote.
180. I have found that a bin lift device can consist of the lifting device of a robot operating above an empty column – empty save for the robot's load. The pick station therefore has a bin lift device. It satisfies the relevant integer of claim 11.

Tote-out machine

181. A tote-out machine, or TOM, conveys delivery totes from a robot at the top of the grid to a delivery station at the bottom, from where the tote is horizontally transmitted to an area for collection.
182. The robot lowers the nested tote down the arrival column to the upper demerger position. Here the delivery tote is held while the hive tote is lowered and thereby separated from the delivery tote. The hive tote is moved horizontally to the departure column while the delivery tote remains in the arrival column. The delivery tote is then lowered down the arrival column by a vertical conveyor to a horizontal conveyor at the bottom and thence out of the system. The bin lifting

is thus done in small part by the robot and in principal part by the TOM vertical conveyor.

183. For convenience, I quote here the relevant part of claim 11 of EP 794. The storage system comprises:

“... a bin lift device arranged to convey a vehicle delivered storage bin in a direction perpendicular to the lateral plane of the vehicle support between the vehicle support and a delivery station.”

184. I have found as a matter of construction that storage bins within the meaning of claim 11 must be stackable. In its closing submissions Ocado’s first point was that delivery totes are not stackable and are consequently not “storage bins” within the meaning of claim 11. Ocado also asserted that the robots, the components of the system which do the stacking, cannot pick up delivery totes. The TOM vertical conveyor moves only delivery totes, so cannot be said to convey a storage bin within the meaning of claim 11. Ocado should know their own system, but no evidence was cited in support of these assertions, specifically that delivery bins are not stackable.
185. AutoStore, in its written closing submissions, asserted the opposite. It said that that delivery totes are “stored in a storage column of the storage system as part of a vertical stack of bins”, implying that the delivery totes stacked on top of each other. Again, no evidence was cited.
186. I had to resort to Ocado’s PPD, a document which runs to 189 pages, packed with as much detail as anyone could wish for. Paragraph 5 states that the totes which are stacked in the OSP system are hive totes. There is later in the PPD a photograph of hive totes (white) in which delivery totes (red) have been nested. The delivery totes are shown containing customer orders in plastic bags:



187. The description of how the TOM works at paragraph 279 confirms that it is the hive totes which are stacked, although they will sometimes have delivery totes nested within them.

188. I conclude that delivery totes are stored vertically on top of each other in stacks, but only inside hive totes and it is the latter which appear to take the weight and so must be robust enough to be stackable. I accept Ocado's submission that the robots cannot pick up delivery totes.
189. I agree with Ocado that the delivery totes are not storage bins within the meaning of claim 11. The TOM vertical conveyor does not convey storage bins within the meaning of that claim.
190. Ocado's second argument was that even if the delivery totes were storage bins, the vertical conveyor does not convey them between the vehicle support and a delivery station. The vehicle support is the structure at the top of the grid which supports the robots. The vertical conveyor conveys the delivery totes not from there, but from the upper demerger position down to a delivery station.
191. AutoStore pointed to evidence from Professor Fottner in which he said that a robot must drop the bin from its central cavity to a level below the vehicle support in order for the robot to move away. As a matter of normal construction, the vertical conveyor does not convey the bin from the vehicle support. AutoStore did not formulate an argument on equivalents. I find that the TOM has no bin lift device arranged to convey a storage bin between the vehicle support and a delivery station within the meaning of claim 11 of EP 794.
192. For the foregoing two reasons, the TOM does not satisfy the claim.

Delivery-tote machine

193. In a delivery-tote machine ("DTM") the robot lowers a nested tote down the arrival column to the arrival position. The nested tote is then moved to the bottom of the departure column where the delivery tote is removed from the hive tote. Two vertical conveyors move the hive tote up the departure column to the lower merger position. An empty delivery tote is held at the upper merger position. The hive tote is lifted further into the upper merger position by a third vertical conveyor and in so doing embraces the delivery tote to make a nested tote. This nested tote is lifted by the third vertical conveyor to the departure position, from where a robot lifts it up and out of the departure column.
194. Ocado had three arguments. The first was the same as advanced in respect of the TOM, namely that a bin lift device cannot consist of the lifting device of a robot operating above an empty column. I have found as a matter of construction that it can.
195. The second and third arguments concerned the means for lifting the hive tote to the departure position. Ocado submitted that this arrangement is not within claim 11 because (a) the tote is not "vehicle delivered" at the bottom of the departure column but delivered by a horizontal conveyor and (b) the hive tote is conveyed from the bottom of the column to the departure position, not the vehicle support level.

196. I have accepted argument (b) in relation to the TOM. As to (a), the vehicle in claim 11 is a robot and Ocado is right to say that the bin is not conveyed to the bottom of the departure column by a robot.
197. However, the robot operating over the arrival column has a bin lift device which conveys a bin “between the vehicle support and a delivery station”. This is sufficient to satisfy the relevant integer of claim 11.

Combination-separation machine

198. Ocado’s argument in relation to the combination-separation machine (“CSM”) was the same as in relation to the pick station. The result is the same: it has a bin lift device.

VALIDITY

199. Ocado’s attack on the validity of the Central Cavity Patents fell into two distinct parts.
200. One was that either or both of two disclosures made by AutoStore in Russia before the priority date rendered the patents lacking in novelty. AutoStore accepted that the disclosures had been made and further accepted that if they were made in law without any obligation of confidence on the part of the recipients of the relevant information, both Central Cavity Patents lacked novelty and/or inventive step.
201. The other part of Ocado’s case on novelty was an allegation that the Central Cavity Patents lacked inventive step over a single item of prior art.

Factual background to the alleged prior disclosures

202. The Central Bank of the Russian Federation, also known as the Bank of Russia, is the main financial institution of the Russian government, set up under the Russian Constitution. It took on its present form in 1990 but traces its history back to the foundation of the State Bank of the Russian Empire in 1860.
203. EVS is a company founded in St Petersburg in 1990 which deals in storage and security systems for banks and other entities.
204. In early 2010 representatives of the Bank became aware of AutoStore’s automatic storage system, shown at the Logimat trade fair in Stuttgart. On 17 March 2010 Konstantin Kochetkov, Deputy Chief of Division in the Cash Circulation Department of the Bank, emailed Mr Hjorteland, AutoStore’s Vice President for Sales, expressing an interest in the system and asking whether it could be inspected by representatives of the Bank in June 2010. At about the same time the Bank instructed EVS to look into AutoStore’s system and to see whether it would be compatible with the Bank’s requirements. The Bank had mostly in mind a system for the automatic storage and handling of currency, as opposed to heavy items such as gold bullion.

205. On 19 March 2010 Mr Kutsenko of EVS emailed Mr Hjorteland, introducing himself. From then on Mr Kutsenko represented EVS in negotiations with AutoStore. Mr Kutsenko speaks fluent English, the language in which the negotiations with AutoStore were carried out. He reported back to Mr Konstantinov, who was senior to him in EVS and who has limited English. Mr Konstantinov was responsible for EVS's relationship with the Bank. Mr Kutsenko had no direct contact with the Bank and always received his instructions via Mr Konstantinov.
206. On 2 and 3 June 2010 Mr Konstantinov and Mr Kutsenko visited AutoStore's headquarters in Nedre Vats, Norway. They inspected AutoStore's technology and discussed what the Bank needed. On 22 June 2010 AutoStore sent EVS an estimate of the development costs of meeting the Bank's requirements. Ten days later Mr Kutsenko replied, asking AutoStore to justify these costs, which he described as "huge money".

The July 2010 Email

207. Mr Hjorteland responded by email on 5 July 2010 ("the July 2010 Email"). He explained that the Bank's wish to continue use of its existing bins would mean that AutoStore would have to develop a new system. Three stylised computer-generated sketches were attached showing the proposed designs that AutoStore were working on in this regard. This is the July 2010 Email with content that was designated confidential at the trial deleted:

To: Michael Kutsenko [kutsenko@evs.ru]

From: Sven Åge Hjorteland ...

Sent: Mon 7/5/2010 8:51:48 AM (UTC)

Subject: CBR – development

[Links to 3 design drawings]

Hello Michael,

Ref. your email regarding development cost for the CBR project.

We have based on our meeting and discussions in Norway evaluated the CBR request for AutoStore in details. In our view we have to do a new development to be able to deliver a system that fits CBR's requests and task. The main development is based on the request that we have to use the existing CBR bin. I have attached the drawing for the new robot design we are working on for the CBR project.

New robot design:

[Deleted]

New grid design:

[Deleted]

Port:

[Deleted]

Control software development:

[Deleted]

Included in the development cost we have also included a test grid and 2 robots so you (EVS) can test your part of the software on a real test system.

Hope that this has explained the development cost, and if you have any further questions or comments please don't hesitate to contact me.

Best Regards

Sven Åge Hjorteland

Managing Director

Jakob Hatteland Computer AS

[Phone numbers]

www.hatteland.com

Please note that this message may contain confidential information. If you have received this message by mistake, please inform the sender of the mistake by sending a reply, then delete the message from your system without making, distributing or retaining any copies of it.

[Virus warning]"

208. Mr Konstantinov said that he did not recall seeing the July 2010 Email when it was received although he probably discussed its contents with Mr Kutsenko. He added that he did not pass the contents of the email to the Bank because he did not think that the Bank would have found the contents useful at that time.

The parties' views regarding the July 2010 Email and confidentiality

209. Mr Hjorteland described the initial meeting between AutoStore, the Bank and EVS on 2-3 June 2010:

“... it was, as I said, a normal practice in AutoStore to keep all discussions with clients confidential and, in this case, it was the Central Bank of Russia and I will see them as a very sensitive organisation and our discussion with the Central Bank, so for me it was, yes, strictly confidential, the discussions that we had with EVS and CBR.”

210. I can well understand that AutoStore regarded the Bank as a particularly sensitive client. This suggests that AutoStore would have been very cautious about disclosing anything in the meeting with a third party. It says nothing about AutoStore's attitude to information subsequently disclosed to the Bank and EVS. Mr Kutsenko's evidence was that the technical information disclosed by AutoStore at the meeting was "usual marketing technical information".
211. However, matters moved on. EVS wanted AutoStore to justify its "huge money" development costs and this led to the July 2010 Email with its description of the development work to be done and the three attachments showing the Bank Bot Design.
212. Mr Hjorteland, Mr Konstantinov and Mr Kutsenko were all clear in their respective witness statements that at all relevant times they regarded the contents of the July 2010 Email as being confidential. They maintained this in cross-examination.

The September 2011 Meeting

213. Little seems to have happened after the July 2010 Email until Mr Kutsenko met Mr Hjorteland at a trade fair in Hannover in May 2011. This led to discussions between AutoStore and EVS about the terms of a distribution agreement.
214. On 27-29 September 2011, representatives of AutoStore, EVS and the Bank met at AutoStore's premises at Nedre Vats in Norway ("the September 2011 Meeting"). AutoStore gave a slide presentation, including the three images of the system sent with the July 2010 Email and other images giving further details of the distribution system which AutoStore said could be developed for the Bank. Mr Konstantinov said that this was the first occasion on which the Bank saw any of those images.
215. Mr Hjorteland, Mr Konstantinov and Mr Kutsenko were all adamant that the information disclosed by AutoStore at the September 2011 Meeting was treated by the parties as confidential.

The Distribution Agreement

216. On 18 November 2011 EVS and AutoStore entered into a distribution agreement ("the Distribution Agreement"), which was stated to have taken effect from 24 May 2011. It contained a term that the Distribution Agreement was to be governed by Norwegian law.
217. Notwithstanding the Distribution Agreement, the Bank appears to have had misgivings about the price which AutoStore wished to charge. The September 2011 Meeting was followed by only intermittent discussions for well over a year. But agreement was finally reached and AutoStore systems were delivered through EVS to the Bank in 2013.

The genesis of the Distribution Agreement

218. Mr Hjorteland set out five reasons in his witness statement why the contents of the July 2010 Email were treated by him as being confidential (he called it “the 5 July meeting” but in context he must have meant the 5 July Email). The reasons included this:

“13. ... Finally, I knew that EVS was interested in becoming a distributor for AutoStore in Russia, and it would have been against their interests for these discussions to be treated as other than confidential.”

219. Mr Konstantinov said that one of the reasons that the discussions with AutoStore in Nedre Vats on 2-3 June 2010 were confidential was that EVS intended to enter into a distributorship agreement with AutoStore. It was put to Mr Konstantinov in cross-examination that there were no negotiations about the terms of the Distribution Agreement in the period between June 2010 and June 2011 when Mr Hjorteland sent a first draft to EVS. Mr Konstantinov’s reply was not altogether clear, but I understand him to have meant that no terms were discussed in that period.

220. Mr Kutsenko said in cross-examination that it was only after the meeting at the Hanover trade fair in May 2011 that he started to discuss the terms of a distribution agreement.

221. I find that a distribution agreement was in the contemplation of both AutoStore and EVS at the time of the July 2010 Email as a consequence of discussions in Nedre Vats the month before. However, no consideration was given to the wording of terms until June 2011.

The issue in relation to the alleged prior disclosures and foreign law

222. In support of their case of lack of novelty and inventive step Ocado rely on what they call “the Bank Bot prior disclosures”. There is no need to distinguish the information in the two disclosures, alleged to have been made to EVS on two occasions, namely by the July 2010 Email and at the September 2011 Meeting.

223. The contents of the 2010 Email were not communicated to the Bank. The Bank did not receive the relevant information until the September 2011 Meeting.

224. Ocado plead that in the 2010 Email and at the 2011 Meeting AutoStore disclosed what they call “the Bank Bot Design”, which is defined by Ocado as Bank Bots:

“... designed to function as remotely operated vehicles for picking up storage bins from a storage system and comprise inter alia a device for lifting storage bins into a centrally arranged cavity, a set of wheels allowing movement of the vehicle in the X direction within the storage system, a set of wheels allowing movement of the vehicle in the Y direction within the storage system and at least one set of wheels arranged fully within the vehicle body”.

225. In the Re-Re-Re-Re-Amended Reply and Defence to Counterclaim AutoStore does not deny that the Bank Bot Design was disclosed in both the 2010 Email

and in the September 2011 Meeting as alleged. At the trial counsel for AutoStore went further with a formal admission to this effect. AutoStore also admitted that the Bank Bot Design was an enabling disclosure of the invention claimed in EP 794. However, AutoStore say that the Bank Bot Design was disclosed on both occasions under an obligation of confidence.

226. Thus, if the disclosure of the Bank Bot Design was not made under an obligation of confidence, either by the July 2010 Email or at the September 2011 Meeting, EP 794 lacks novelty. AutoStore also accepted that in those circumstances EP 027 lacks either novelty or inventive step.

Section 2(2) of the Patents Act 1977 and Making Available to the Public

227. Subsections 2(1) and (2) of the Patents Act 1977 (“the 1977 Act”) provide:

“2. (1) *An invention shall be taken to be new if it does not form part of the state of the art.*

(2) *The state of the art in the case of an invention shall be taken to comprise all matter (whether a product, a process, information about either, or anything else) which has at any time before the priority date of that invention been made available to the public (whether in the United Kingdom or elsewhere) by written or oral description, by use or in any other way.”*

228. The criterion of matter being “made available to the public” in section 2(2) determines the state of the art in relation to a UK patent and a UK designated European Patent. That criterion is not affected by the place where the disclosure of any matter occurs, or by the domicile or location of either the discloser or recipient of the disclosure. Before considering whether and how the application of this criterion may be influenced by foreign law, I need to say more about the criterion in English law.

229. “Matter” in this context means information. In *Merrell Dow Pharmaceuticals Inc. v H.N. Norton & Co Ltd* [1996] RPC 76, Lord Hoffmann said (at 86):

“An invention is a piece of information. Making matter available to the public within the meaning of section 2(2) therefore requires the communication of information.”

230. The phrase “made available to the public” first appeared in a statute in s.4(b) of the Patents and Designs Act 1919. With one important qualification, the meaning of information being “made available to the public” has remained unchanged in law since the validity of a patent was governed solely by common law. In *Humpherson v Syer* (1887) 4 RPC 407 (CA) Bowen LJ stated that information is made available to the public if it is:

“... communicated to any member of the public who was free in law or equity to use it as he pleased” (at 413).

231. The next sentence of Bowen LJ's judgment makes clear that he had in mind that the member of the public must be free in law *and* equity to use the information and that such a person must be free to do anything he liked, which would include not just use but disclosure:

“Was *Widmer* a person to whom this communication had been made in a manner which left him free both in law or equity to do what he liked with the information”.

232. In *Yeda Research and Development Co Ltd v Rhone-Poulenc Rorer International Holdings Inc* [2007] UKHL 43, Lord Walker said (at [62]):

“Where a patentable invention is imparted in confidence...it does not amount to publication since (in the hallowed words used by Bowen LJ in *Humpherson v Syer* (1887) 4 R.P.C. 407, 413) the recipient of the information is not ‘free in law and equity to use it as he pleased.’”

233. The qualification I referred to earlier is that since the coming into force of the 1977 Act, information is made available to the public if such availability occurred anywhere in the world. The rule of local novelty which applied before then required that the information had been made available within the jurisdiction, later the United Kingdom.

234. Since *Humpherson* the courts have further explained and refined the concept of making available to the public.

235. First, the information which constitutes the invention need only be made available to one member of the public who is free in law or equity to use it, see *R v Patents Appeal Tribunal* [1968] 1 WLR 1727, per Lord Parker CJ at 1734-5. Jacob LJ referred to Lord Parker's judgment in *Green Lane Product Limited v PMS International Group Limited* [2008] EWCA Civ 358, at [22]:

“The argument that the question of whether a document was made available to the public was one of fact and degree was decisively rejected. I think that was a good thing: it provided a bright-line workable rule which has served the test of time. Expensive investigation of not only whether a piece of prior art was known but how well known it was known is obviated. The small price of the occasional harsh decision is well worth it for the sake of a cohesive and predictable system.”

236. Secondly, the test is whether the information was made available, not whether it was accessed by anyone, see *Lux Traffic Controls Ltd v Pike Signals Ltd* [1993] RPC 107, at 133. It is not even relevant whether any person would have realised that the information was available. In *Unilin Beheer BV v Berry Floor NV* [2007] EWCA Civ 364, at [26] Jacob LJ gave his “favourite pretend example” of an invention lacking in novelty solely because of information contained in a document:

“... written in Sanskrit wrongly placed in the children's section of Alice Springs public library ...”

237. Thirdly, an ephemeral disclosure will suffice, such as an oral disclosure to a person who dies shortly afterwards, see *Richter Gedeon Vegyeszeti Gyar RT v Generics (UK) Ltd* [2016] EWCA Civ 410, at [14]-[16].
238. Fourthly and related to the previous point, the question whether information has been made available to the public within the meaning of s.2(2) of the 1977 Act is to be assessed at the alleged moment of its being made available. Once the cat is out of the bag, the cat stays out. Information made available to the public remains part of the state of the art even if public access to it is subsequently withdrawn, see *Generics (UK) Ltd v Daiichi Pharmaceutical Co Ltd* [2008] EWHC 2413 (Pat), at [182].
239. Fifthly, the burden of proving that information has been made available to the public rests on the party asserting that this is the case, though the evidential burden may shift. In *Qualcomm Inc v Nokia Corp* [2008] EWHC 329 (Pat), Floyd J said:
- “[113] The burden of proving that matter was made available to the public lies with the party asserting it, i.e. Nokia. Mr Silverleaf tried to unload the burden onto Qualcomm to prove the contrary by submitting that once distribution of a document had been proved, the burden shifted. That cannot be right as a general proposition. If what is proved is distribution through a channel which would normally be expected to make the document available to the public, then the burden will shift, at least temporarily. But if what is proved is distribution through an unconventional channel, particularly one where precautions to maintain confidentiality of some kind were taken, the burden will remain with the party seeking to establish that the document was made available to the public.”
240. Sixthly, the standard of proof is the usual standard of the balance of probabilities, see *Kavanagh Balloons Pty Ltd v Cameron Balloons Ltd* [2004] RPC 5, at [51]-[58].

Information imparted in confidence

241. An obligation of confidence may be imposed on the recipient of information contractually as well as in equity. A contractual requirement not to disclose information may be express or implied.
242. Contractual restrictions aside, the test for whether a recipient of information is free to use it is whether they are under an equitable duty not to do so. In *Coco v A.N. Clark (Engineers) Ltd* [1968] FSR 415, Megarry J set out his well-known three elements of a breach of an equitable obligation of confidence (at 419-421). First the information in question must be of a confidential nature. Secondly, it must have been communicated in circumstances importing an obligation of confidence. Thirdly, there must be an unauthorised use of the information to the detriment of the person communicating it. In *The Racing Partnership Ltd v Done Brothers (Cash Betting) Ltd* [2020] EWCA Civ 1300, Arnold LJ said (at [45]) that Megarry J’s statement of law:

“has repeatedly been cited with approval at the highest level: see Lord Griffiths in *Attorney General v Guardian Newspapers Ltd (No 2)* [1990] 1 AC 109, 268, Lord Nicholls of Birkenhead in *Campbell v MGN Ltd* [2004] 2 AC 457, para 13 and Lord Hoffmann in *Douglas v Hello! Ltd (No 3)* [2008] AC 1, para 111 . (It is not, however, a complete statement of the ingredients of a successful claim: there is a further requirement, namely that the unauthorised use of information was without lawful excuse.)”

243. In the present case there is no claim to a lawful excuse.

244. In *The Racing Partnership* Arnold LJ referred (at [48]) to the analysis of the cases on the necessary quality of confidence set out in Chapter 5 of Aplin et al, *Gurry on Breach of Confidential Information*, 2nd ed.:

“As the authors’ analysis makes clear, the issue is context- and fact-sensitive, and confidentiality is a relative and not an absolute concept. They identify the basic attribute which information must possess before it can be considered confidential as being inaccessibility: see paras 5.14 to 5.20. I agree with this.”

245. Megarry J explained his second element in this way:

“It may be that that hard-worked creature, the reasonable man, may be pressed into service once more; for I do not see why he should not labour in equity as well as at law. It seems to me that if the circumstances are such that any reasonable man standing in the shoes of the recipient of the information would have realised that upon reasonable grounds the information was being given to him in confidence, then this should suffice to impose upon him the equitable obligation of confidence. In particular, where information of commercial or industrial value is given on a business-like basis and with some avowed common object in mind, such as a joint venture or the manufacture of articles by one party for the other, I would regard the recipient as carrying a heavy burden if he seeks to repel a contention that he was bound by an obligation of confidence”

246. This is consistent with the principle later advanced by Lord Goff in *Attorney General v Observer Ltd* [1990] AC 109. In that case the author of the book *Spycatcher* and certain newspapers were held to have been in breach of a duty of confidentiality owed to the Crown. Lord Goff said, at 281:

“I start with the broad general principle (which I do not intend in any way to be definitive) that a duty of confidence arises when confidential information comes to the knowledge of a person (the confidant) in circumstances where he has notice, or is held to have agreed, that the information is confidential, with the effect that it would be just in all the circumstances that he should be precluded from disclosing the information to others.”

247. The authors of *Gurry* suggest (at paragraph 7.37) circumstances which will be relevant to the objective assessment of whether the information was received with knowledge or notice that it was confidential (here omitting footnotes to supporting authority):

“The relevant factors for establishing such knowledge or notice include: the nature of the information (whether it is banal, trivial, common knowledge, commercially valuable, or intimately personal); the steps taken to preserve or emphasize the secrecy of the information (eg whether it is marked ‘confidential’ or ‘private’; or if special care is taken that there is a restricted disclosure to others); the manner in which the information was disclosed or obtained (whether it is informal, social commercial, or professional); the understanding of the parties involved (ie did they in fact regard the information as confidential or themselves as being under an obligation of confidence); and where the information is disclosed for a specific, limited purpose and it is understood, from the legal and cultural context of the disclosure, that the information will not be used for another purpose. In other words, the ‘limited purpose’ of the disclosure is a factor to be considered as part of the ‘notice of confidentiality’ test.”

English case law on the application of foreign law

248. I was referred to just one authority in which the application of foreign law to the question of making available to the public under section 2(2) was considered. The agreement on the law between the parties in that case meant that there was no need to explore the matter in any depth.
249. In *Thoratec Europe Ltd v AIS GmbH Aachen Innovative Solutions* [2016] EWHC 2637 (Pat) the claimant, Thoratec, sought revocation and a declaration of non-infringement in respect of two patents owned by the defendant, AIS. One ground of revocation was an alleged prior use in the Netherlands by means of the disclosure there of a device to a Dr Dekker and his colleagues. AIS contended that Dr Dekker and his colleagues were subject to an implied obligation of confidence under Dutch law. This does not appear to have been an allegation that there was an implied contractual term, but that the obligation was to be implied as a matter of Dutch law from the circumstances in which the information was obtained or received. It also appears that the parties agreed that Dutch law was applicable; no reasoning was given. Arnold J found (at [178]) that a presumption in Dutch law that the information was subject to an implied duty of confidentiality was firmly rebutted on the evidence.

The European Patent Office

250. Section 2 of the 1977 Act is among those cited in section 130(7) and consequently must be given, as nearly as practicable, the same effect as the corresponding provision of the European Patent Convention (“EPC”). The provision corresponding to s.2(2) is art.54(2):

(2) *The state of the art shall be held to comprise everything made available to the public by means of a written or oral description, by use, or in any other way, before the date of filing of the European patent application.*

251. English courts must have regard to relevant decisions of the European Patent Office (“EPO”) on the construction of the EPC, which decisions will be of great persuasive authority, see *Merrell Dow Pharmaceuticals Inc v H.N. Norton & Co Ltd* [1996] RPC 76, per Lord Hoffmann at [82]. Although a national court may reach a conclusion different to that of an Opposition Division or Board of Appeal on different evidence or a different evaluation of the evidence, the principles of law should be taken to be the same, see *Human Genome Sciences, Inc v Eli Lilly & Co* [2011] UKSC 51, per Lord Neuberger at [83]-[86].
252. A summary of the approach taken by the EPO to confidentiality and making information available to the public can be found in the *Guidelines for Examination* published in March 2022, Part G – Patentability, Chapter IV, paragraph 7.2.2 headed “Agreement on secrecy” (“the division” refers to the Examining Division of the EPO when considering an application for a European Patent):

“The basic principle to be adopted is that subject-matter has not been made available to the public by use or in any other way if there is an express or tacit agreement on secrecy which has not been broken.

In order to establish whether there is a tacit agreement, the division must consider the particular circumstances of the case especially whether one or more parties involved in the prior use had an objectively recognisable interest in maintaining secrecy. If only some of the parties had such an interest, it must be established if the other parties implicitly accepted to act accordingly. For example, this is the case when the other parties could be expected to maintain secrecy in accordance with the usual business practice in the relevant industry. For establishing a tacit agreement important aspects to be considered are, *inter alia*, the commercial relationship between the parties and the exact object of the prior use. The following may be indicators of a tacit secrecy agreement: A parent company – subsidiary relationship, a relationship of good faith and trust, a joint venture, the delivery of test specimens. The following may be indicators of the absence of such an agreement: An ordinary commercial transaction, the sale of parts for serial production.”

253. There is no reason to doubt that the concept of an express agreement in the Guidelines is the same as a contractual agreement in English law. It seems to me that the “tacit agreement” of the Guidelines equates at least in part to one alternative route under English law, namely an implied contractual term of confidentiality. The principles of law developed by the EPO do not, of course, include the English notion of equity, but I think that the circumstances which give rise to an equitable obligation of confidence in English law would also qualify as a tacit agreement recognised by the EPO.

254. The section of the Guidelines I have quoted assumes that the information has not otherwise been made available to the public and is thus of a confidential nature, satisfying Megarry J's first element. The quoted section deals with the second element. The Guidelines indicate that all relevant circumstances must be considered in assessing whether there has been a tacit agreement. Similarly, English law requires all relevant circumstances to be considered in assessing whether Megarry J's second element is satisfied.
255. Put another way, all relevant circumstances must be taken into account in giving an answer to Megarry J's implied question: would any reasonable man standing in the shoes of the recipient of the information have realised upon reasonable grounds that the information was being given to him in confidence?

TRIPs

256. English law and the EPO approach to confidentiality are consistent with art.38(2) of the Agreement on Trade-Related Aspects of Intellectual Property Rights, as amended on 23 January 2017:

“2. Natural and legal persons shall have the possibility of preventing information lawfully within their control from being disclosed to, acquired by, or used by others without their consent in a manner contrary to honest commercial practices¹⁰ so long as such information:

(a) is secret in the sense that it is not, as a body or in the precise configuration and assembly of its components, generally known among or readily accessible to persons within the circles that normally deal with the kind of information in question;

(b) has commercial value because it is secret; and

(c) has been subject to reasonable steps under the circumstances, by the person lawfully in control of the information, to keep it secret.”

257. Footnote 10 reads:

“For the purpose of this provision, ‘a manner contrary to honest commercial practices’ shall mean at least practices such as breach of contract, breach of confidence and inducement to breach, and includes the acquisition of undisclosed information by third parties who knew, or were grossly negligent in failing to know, that such practices were involved in the acquisition.”

ROME I and ROME II

258. There was disagreement between the parties regarding the application of foreign law to making matter available to the public on the facts of this case. The points at issue were whether Regulation (EC) no. 864/2007 of 11 July 2007 on the law applicable to non-contractual obligations (“Rome II”) is engaged and if so, which article of Rome II.

259. Rome II is retained EU legislation pursuant to the European Union (Withdrawal) Act 2018 (“the 2018 Act”) and the Law Applicable to Contractual and Non-Contractual Obligations (Amendment etc.) (EU Exit) Regulations 2019/834 (“the 2019 Regulations”).
260. Similarly, Regulation (EC) No. 593/2008 of 17 June 2008 on the law applicable to contractual obligations (“Rome I”), also referred to in argument, is preserved as part of English law by the 2018 Act and the 2019 Regulations.
261. Rome II provides in relevant part:

“CHAPTER 1

SCOPE

Article 1

Scope

1. *This Regulation shall apply, in situations involving a conflict of laws, to non-contractual obligations in civil and commercial matters. It shall not apply, in particular, to revenue, customs or administrative matters or to the liability of the State for acts and omissions in the exercise of State authority (acta iure imperii).*
2. *The following shall be excluded from the scope of this Regulation:*
 - (a) *non-contractual obligations arising out of family relationships and relationships deemed by the law applicable to such relationships to have comparable effects including maintenance obligations;*
 - (b) *non-contractual obligations arising out of matrimonial property regimes, property regimes of relationships deemed by the law applicable to such relationships to have comparable effects to marriage, and wills and succession;*
 - (c) *non-contractual obligations arising under bills of exchange, cheques and promissory notes and other negotiable instruments to the extent that the obligations under such other negotiable instruments arise out of their negotiable character;*
 - (d) *non-contractual obligations arising out of the law of companies and other bodies corporate or unincorporated regarding matters such as the creation, by registration or otherwise, legal capacity, internal organisation or winding-up of companies and other bodies corporate or unincorporated, the personal liability of officers and members as such for the obligations of the company or body and the personal liability of auditors to a company or to its members in the statutory audits of accounting documents;*

- (e) *non-contractual obligations arising out of the relations between the settlors, trustees and beneficiaries of a trust created voluntarily;*
 - (f) *non-contractual obligations arising out of nuclear damage;*
 - (g) *non-contractual obligations arising out of violations of privacy and rights relating to personality, including defamation.*
- ...

Article 2

Non-contractual obligations

1. *For the purposes of this Regulation, damage shall cover any consequence arising out of tort/delict, unjust enrichment, negotiorum gestio or culpa in contrahendo.*
2. *This Regulation shall apply also to non-contractual obligations that are likely to arise.*
3. *Any reference in this Regulation to:*
 - (a) *an event giving rise to damage shall include events giving rise to damage that are likely to occur; and*
 - (b) *damage shall include damage that is likely to occur.*

Article 3

Universal application

Any law specified by this Regulation shall be applied whether or not it is the law of a Member State.

CHAPTER II

TORTS/DELICTS

Article 4

General rule

1. *Unless otherwise provided for in this Regulation, the law applicable to a non-contractual obligation arising out of a tort/delict shall be the law of the country in which the damage occurs irrespective of the country in which the event giving rise to the damage occurred and irrespective of the country or countries in which the indirect consequences of that event occur.*

2. *However, where the person claimed to be liable and the person sustaining damage both have their habitual residence in the same country at the time when the damage occurs, the law of that country shall apply.*

3. *Where it is clear from all the circumstances of the case that the tort/delict is manifestly more closely connected with a country other than that indicated in paragraphs 1 or 2, the law of that other country shall apply. A manifestly closer connection with another country might be based in particular on a preexisting relationship between the parties, such as a contract, that is closely connected with the tort/delict in question.*

...

Article 6

Unfair competition and acts restricting free competition

1. *The law applicable to a non-contractual obligation arising out of an act of unfair competition shall be the law of the country where competitive relations or the collective interests of consumers are, or are likely to be, affected.*

2. *Where an act of unfair competition affects exclusively the interests of a specific competitor, Article 4 shall apply.*

3. (a) *The law applicable to a non-contractual obligation arising out of a restriction of competition shall be the law of the country where the market is, or is likely to be, affected.*

(b) *When the market is, or is likely to be, affected in more than one country, the person seeking compensation for damage who sues in the court of the domicile of the defendant, may instead choose to base his or her claim on the law of the court seised, provided that the market in that Member State is amongst those directly and substantially affected by the restriction of competition out of which the non-contractual obligation on which the claim is based arises; where the claimant sues, in accordance with the applicable rules on jurisdiction, more than one defendant in that court, he or she can only choose to base his or her claim on the law of that court if the restriction of competition on which the claim against each of these defendants relies directly and substantially affects also the market in the Member State of that court.*

4. *The law applicable under this Article may not be derogated from by an agreement pursuant to Article 14.*

...

CHAPTER III

**UNJUST ENRICHMENT, NEGOTIORUM GESTIO AND CULPA
IN CONTRAHENDO**

...

Article 12

Culpa in contrahendo

1. *The law applicable to a non-contractual obligation arising out of dealings prior to the conclusion of a contract, regardless of whether the contract was actually concluded or not, shall be the law that applies to the contract or that would have been applicable to it had it been entered into.*
2. *Where the law applicable cannot be determined on the basis of paragraph 1, it shall be:*
 - (a) *the law of the country in which the damage occurs, irrespective of the country in which the event giving rise to the damage occurred and irrespective of the country or countries in which the indirect consequences of that event occurred; or*
 - (b) *where the parties have their habitual residence in the same country at the time when the event giving rise to the damage occurs, the law of that country; or*
 - (c) *where it is clear from all the circumstances of the case that the non-contractual obligation arising out of dealings prior to the conclusion of a contract is manifestly more closely connected with a country other than that indicated in points (a) and (b), the law of that other country.*

...

Article 14

Freedom of choice

1. *The parties may agree to submit non-contractual obligations to the law of their choice.*
 - (a) *by an agreement entered into after the event giving rise to the damage occurred;*

or

(b) *where all the parties are pursuing a commercial activity, also by an agreement freely negotiated before the event giving rise to the damage occurred.*

The choice shall be expressed or demonstrated with reasonable certainty by the circumstances of the case and shall not prejudice the rights of third parties.

2. *Where all the elements relevant to the situation at the time when the event giving rise to the damage occurs are located in a country other than the country whose law has been chosen, the choice of the parties shall not prejudice the application of provisions of the law of that other country which cannot be derogated from by agreement.*
3. *Where all the elements relevant to the situation at the time when the event giving rise to the damage occurs are located in one or more of the Member States, the parties' choice of the law applicable other than that of a Member State shall not prejudice the application of provisions of Community law, where appropriate as implemented in the Member State of the forum, which cannot be derogated from by agreement*

...

Article 24

Exclusion of renvoi

The application of the law of any country specified by this Regulation means the application of the rules of law in force in that country other than its rules of private international law.

...

Article 28

Relationship with existing international conventions

1. *This Regulation shall not prejudice the application of international conventions to which one or more Member States are parties at the time when this Regulation is adopted and which lay down conflict-of-law rules relating to non-contractual obligations.*

... ”

Making matter available to the public in a foreign context

262. As I have said, matter made available to the public in any part of the world forms part of the state of the art within the meaning of s.2(2) of the 1977 Act and may therefore affect the novelty or obviousness of a UK patent.

263. Where a party relies on an express contractual restriction on the foreign disclosure of information, the effect of the alleged contract will be assessed according to the applicable law. The party asserting the contractual restriction is obliged to plead the existence, the circumstances of formation and the relevant terms of the contract. An English court seised will apply Rome I to determine which foreign law governs the contract. The court will then decide whether, according to that law, there was an express term of confidentiality as alleged and whether its effect was to restrict the use of the information in issue.
264. Similarly, if a party relies on an implied term in a contract in support of its case on the confidentiality of information, an English court will identify the applicable law by reference to Rome I and then resolve whether, in light of the principles of that law and the relevant facts, the term in issue was implied as alleged and if so, whether its effect under the relevant law was to restrict use of the information.

Whether Rome II applies

265. The position is not so straightforward where it is said that a party in a foreign context was restrained from using information under an obligation that was not contractual – what an English court would recognise as an equitable obligation.

The Arguments

266. It was common ground that although Rome II does not expressly recognise equitable obligations as a separate category, they are capable of being characterised as a species of non-contractual obligation, see Dicey, Morris & Collins, *The Conflict of Laws*, 16th ed., at 34-089.
267. This notwithstanding, Ocado's primary case was that Rome II does not apply to the present case. There were two strands to the argument. The first was based on the proposition that the issue arising under s.2(2) is solely one of English statutory law and fact and that does not change just because the alleged disclosure happened abroad. Therefore, this court must decide on the present facts whether EVS and the Bank (or either of them) were free in law and equity to use the Bank Bot Design. This falls to be assessed as of the time the Bank Bot Design was received. Freedom in law and equity to use the Bank Bot Design turns on the facts. Those facts are resolved in part by reference to the law of the place of receipt of the information at the time of receipt. Both EVS and the Bank were located in Russia and received the information in Russia. The question is whether either or both were restricted from freely using the Bank Bot Design in Russia at the moment of receipt. Self-evidently, Ocado says, that must be determined by reference to Russian law.
268. Ocado further argued that any other approach to Rome II would not work since it would be necessarily based on a hypothesis. The question whether EVS and the Bank were free to use the Bank Bot Design according to these other approaches depended on (a) a hypothetical disclosure by one or both of EVS and the Bank and then (b) an assessment of which law would govern an action to restrain the disclosure. However, Rome II was drafted on the assumption that

the non-contractual claim in issue is a concrete claim, not a hypothetical one. If one could sanction the application of Rome II to hypothetical cases, the applicable law under Rome II would depend on the facts of the breach hypothesised. On that basis, in the present case one could hypothesise a disclosure of the Bank Bot Design by EVS and/or the Bank anywhere in the world on any conceivable facts. The European legislature cannot have intended the law made applicable under Rome II to depend on an arbitrary hypothesis in that way. Specifically, art.4 of Rome II requires that in general the law applicable is the law of the country in which the damage occurred. According to the hypothetical approach, that law would necessarily vary according to the chosen hypothesis.

269. AutoStore submitted that art.1(1) of Rome II makes its application obligatory as a matter of law where, as here, none of the exceptions in art.1 of Rome II arise on the facts. The scheme of the Rome I and II Regulations is that all obligations in civil and commercial matters fall within the material scope of one or other of them; there is no third category of obligations in civil and commercial matters outside their scope. AutoStore's skeleton argument referred to paragraph 34-016 of Dicey, Morris & Collins, *The Conflict of Laws*, 15th ed.

Discussion

270. Beginning with this last point, the 16th edition of Dicey does not insist that there can be no third category of obligations in civil and commercial matters, see paragraph 34-016 which includes this:

“Accordingly, the defining characteristics of various categories of non-contractual obligation for which the Rome II Regulation provides (principally, tort, unjust enrichment, *negotiorum gestio*, *culpa in contrahendo*) must also be taken into account in delimiting its scope. Indeed, it may well be that there will be some obligations which, properly characterised for the purposes of the two Regulations, are neither ‘contractual’ nor ‘non-contractual’ in the autonomous senses used here”.

271. Neither side argued that equitable obligations of confidence as an entire category fall outside the scope of Rome II and I do not believe that to be the case.
272. The difficulty I have with Ocado's assertion that Rome II does not apply to the circumstances of this case is the submission, emphasised by Ocado more than once, that whether EVS and/or the Bank were free to use the Bank Bot Design is purely a question of statutory law and fact. It is not. The key issue that resolves the test under s.2(2) of the 1977 Act is whether the Bank and/or EVS was free to use the relevant information supplied by AutoStore. It is not a pure question of fact. It can only be assessed by applying the relevant law to the facts, which raises the anterior question: which law is to be applied? Ocado's argument rests on the implied proposition that despite the foreign context of the non-contractual obligation in the present case, no issue of the conflict of law is raised; the applicable law can be decided by a direct application of s.2(2) and

jumping to the conclusion that the relevant law must be the law of the place where the Bank Bot Design was received. The conflict of laws rules are thereby entirely bypassed. I do not accept that proposition.

273. As to Ocado's second argument, Rome II applies to non-contractual obligations. Here the obligations are putative, but they may have been real, depending on the effect of the law applicable under Rome II. The breaches of the obligations by the Bank and EVS and the damage flowing from them are hypothetical. I agree that generally it is necessary to consider damage in the course of applying Rome II – see, for example, the general rule of art.4. I understand Ocado's argument that under the rules of Rome II, the applicable law in this case would depend on arbitrarily chosen facts for the hypothetical breach and thereby where, in particular, damage would occur.
274. However, the putative obligation on each of EVS and the Bank was an obligation not to disclose the Bank Bot Design – as opposed, say, to an obligation not to disclose it to a party in one territory on terms that the information would go no further. The breach must be hypothesised against that obligation. The hypothetical breach would have been the disclosure of the Bank Bot Design anywhere, thereby making it available for use everywhere.
275. On that basis, I see no barrier to the application of Rome II to the present facts. Moreover, as AutoStore points out, art.1(1) of Rome II states that the Regulation *shall* apply (subject to specified exceptions) in situations involving a conflict of laws to non-contractual obligations. It is common ground that an equitable obligation of confidence under English law is a non-contractual obligation within the meaning of Rome II.

Art 12 – *culpa in contrahendo*

276. AutoStore's primary contention is that the hypothetical breach of the alleged equitable obligation of confidence is correctly categorised as a *culpa in contrahendo* within the meaning of art.12 of Rome II.
277. AutoStore pointed out that one reason for accepting the application of art.12 (among others) was that it overcame Ocado's difficulty of the applicable law varying according to the hypothetical facts of the breach of confidence. That is true, but as I have explained, I see no real difficulty and it would not anyway be a reason to apply art.12. The application of art.12 must be considered on its own merits.
278. AutoStore derived some support for its case from *ERGO Insurance SE v If P&C Insurance AS* (Joined Cases C-359/14 and C-475/14) EU:C:2016:40. The Court of Justice of the European Union (CJEU) said:

“[45] As regards the concept of ‘non-contractual obligation’, within the meaning of art.1 of the Rome II Regulation, it must be recalled that the concept of ‘matters relating to tort, delict and quasi-delict’, within the meaning of art.5(3) of the Brussels I Regulation, includes all actions which seek to establish the liability of a defendant and are not related to

a ‘contract’ within the meaning of art.5(1) thereof (judgment in *ÖFAB* [2013] I.L.Pr. 38, [32] and the case law cited). Furthermore, it must be observed, as appears from art.2 of the Rome II Regulation, that that Regulation applies to obligations ensuing from damage, that is to say, any consequence arising out of tort/delict, unjust enrichment, ‘*negotiorum gestio*’ or ‘*culpa in contrahendo*.’

[46] In the light of the above, ‘non-contractual obligation’ must be understood as meaning an obligation which derives from one of the events listed in art.2 of that Regulation, set out in the preceding paragraph of this judgment.”

279. AutoStore’s point was that it is not obvious that a breach of an equitable obligation of confidence is derived from one of the events listed in art.2, whereas *culpa in contrahendo* is mentioned expressly.
280. *Culpa in contrahendo* can be translated as “fault in the formation of a contract”. It is a doctrine developed first in German law, credited to Rudolf von Jhering, the 19th century jurist, and was subsequently adopted in other civil law jurisdictions. It is clear from art.12 itself that it can apply regardless of whether the contract was concluded or not. Where the doctrine is engaged, the law governing the non-contractual obligation in question is the law which applies to the contract, or which would have been applied to the contract had it been concluded. If it is not possible to say which law that would be, art.12(2) provides for a means to determine the applicable law.
281. Dicey gives examples of claims to which art.12 may be directed (16th ed. at 35-093):
- “...fraudulent and negligent misrepresentations and duress which occur during the negotiation of a contract.”
282. The authors of Dicey also give examples of what may not be covered (at 35-093):
- “...where...a misrepresentation is made outside contractual negotiations or where a third party relies on a representation made in connection with a contract concluded between the representor and a different party.”
283. Recital [30] of Rome II states:
- “*Culpa in contrahendo* for the purposes of this Regulation is an autonomous concept and should not necessarily be interpreted within the meaning of national law. It should include the violation of the duty of disclosure and the breakdown of contractual negotiations. Article 12 covers only non-contractual obligations presenting a direct link with the dealings prior to the conclusion of a contract. This means that if, while a contract is being negotiated, a person suffers personal injury, Article 4 or other relevant provisions of this Regulation should apply.”

284. The word *culpa* implies that an act within the scope of art.12 will generally be blameworthy but recital [11] of Rome II states that non-contractual obligations covered by the Regulation include those arising out of strict liability. From an English perspective an innocent misrepresentation, for instance, may be covered, see Dickinson, *The Rome II Regulation: The Law Applicable to Non-Contractual Obligations* (OUP, 2010), at 12.04.
285. There is a significant qualification in recital [30]: art.12 covers only non-contractual obligations presenting a *direct* link with the dealings between the parties. Recital [30] gives an obvious example, drawn from German law, of a personal injury being inflicted during negotiations for a contract. The personal injury would not have a direct link with the negotiations, see Dicey, 16th ed. at 35-090, footnote 513 (unless, presumably, it constitutes duress). Dicey continues in the same paragraph:

“The terminology [of recital [30]] and these various observations suggest that Art.12 will apply to claims which seek to establish the defendant’s responsibility for harmful acts or omissions, for example, non-disclosure, fraudulent or negligent misrepresentations and duress, which take place in the course of the negotiation of the contract. Accordingly other types of claim, for example a claim for the value of services provided in anticipation of a contract, may fall outside Art.12 ...”

AutoStore’s overall argument

286. AutoStore argued that the respective obligations of confidentiality on the part of EVS and the Bank arose in the context of EVS’s negotiations with AutoStore, which ultimately led to the conclusion of the Distribution Agreement dated 24 May 2011 (though signed in November 2011). That agreement was governed by Norwegian law. Consequently, the same law applies to the obligations of confidentiality.

The Bank’s alleged obligation of confidence

287. The difficulty with this argument so far as the Bank is concerned is that there were no negotiations between AutoStore and the Bank. In fact, for its own reasons AutoStore was at some pains to ensure that any agreement reached would be with EVS and not the Bank.
288. AutoStore pointed out that art.12 could apply even if there were no contract. That is true, but it seems to me that it would be contrary to the words of art.12, and the idea behind it, to say that the article is engaged even where there was never any prospect of a contract being concluded.
289. The authors of Dicey make this comment (at 35-093):

“Finally, as the principal connecting factor under Art.12 is the law applicable to a contract (or putative contract), its application may be restricted to claims between the parties (or prospective parties) to that

contract, and not any third party (e.g. an agent) involved in the pre-contractual dealings.”

290. *Avonwick Holdings Ltd v Azitio Holdings Ltd* [2020] EWHC 1844 (Comm) concerned, among other things, a claim based on representations made between parties to the action. Picken J rejected an argument that art.12 applies where the defendant was not a party to the contract concluded after the negotiations:

“[162] As Bryan J noted in *The Republic of Angola and others v Perfectbit Limited and others* [2018] EWHC 965 (Comm) at [200], ‘both the leading texts indicate that a claim by a contracting party against a non-party for misrepresentation or the like can fall outside Article 12’. He was referring here to Dicey, Morris & Collins on the Conflict of Laws (15th Ed.) at paragraph 35-093 (“Scope of Article 12”),

291. Picken J also noted (at [163]) that Bryan J had referred to Dickinson, beginning with paragraph 12.07 which he quoted:

““As the primary connecting factor within Art 12 is the law applicable to a contract, either concluded or contemplated, there is a strong argument for restricting its scope to claims between the (intended) parties to the contract so as to exclude (for example) a claim for damages by one of the parties against the issuer of securities that he has purchased on the market or the agent of another for misrepresentation or as a false procurator. There may, of course, be good reasons for concluding that claims against an agent, whether in contract or in tort/delict, should be governed under the Rome I Regime or Art 4 of the Rome II Regulation by the law of the contract (*lex contractus*), especially if he has taken an active part in negotiations conducted on the basis of drafts containing a choice of law provision. Art 12, however, would appear to contemplate an existing or contemplated contractual relationship between the parties to the non-contractual obligation. That view is consistent, for example, with the approach taken under English law to liability for misrepresentation, providing a separate claim for damages as between the contracting parties only. ...’”

292. Paragraph 12.07 of Dickinson continues with a reference to German law, not quoted by Bryan J or Picken J, which I will come back to.

293. Picken J further quoted from paragraph 12.08:

““The language of Recital (30) ... reduces the significance of comparative analysis of this kind, which in any event is inconclusive. On balance, therefore, claims by or against the representatives of negotiating or contracting parties should be considered to fall outside Art 12, although the contract or supposed contract to which the agent's conduct relates should be considered as a circumstance to be taken into account in applying a flexible rule of displacement such as that in Art 4(3) of the Rome II Regulation or in identifying the law applicable under the Rome I Regime to any contract between agent and counterparty.””

294. AutoStore argued that there remained scope for debate about whether art.12 applies to third parties, referring to German law, Section 311(3) of the *Bürgerliches Gesetzbuch* (BGB), the German Civil Code. This section is quoted by Dickinson at the end of his paragraph 12.07. It reads:

“An obligation with duties under section 241(2) [BGB – an obligation of good faith] may also come into existence in relation to persons who are not themselves intended to be parties to the contract. Such an obligation comes into existence in particular if the third party, by laying claim to being given a particularly high degree of trust, substantially influences the pre-contract negotiations or the entering into of the contract.”

295. AutoStore continued: the Bank must have had an influence on the EVS side of the negotiations. Because the Bank took a material part in the negotiations in that sense, art.12 applies to the Bank’s dealings with AutoStore just as much as it does to EVS’s.

296. I should quote paragraph 12.08 of Dickinson, immediately following his citing of Section 311(3) BGB:

“12.08 The language of recital (30) reduces the significance of comparative analysis of this kind, which in any event is inconclusive. On balance, therefore, claims by or against the representatives of negotiating or contracting parties to be considered to fall outside Art 12, although [reference to the application of art.4(3)].”

297. Recital [30] of Rome II states that the concept of *culpa in contrahendo* under art.12 is autonomous to EU law and should not necessarily be interpreted within the meaning of national law. I cannot assume that if the CJEU were to address this point they would follow German law. Even if it were appropriate for me to be guided by German law, I could not give AutoStore’s submissions in relation to art.311(3) BGB any weight without formal evidence from one or more German lawyers to put that provision into its correct perspective.

298. In summary, Dicey, Dickinson and Picken J are all of the opinion that art.12 does not apply to third parties to the contractual negotiations, even agents (Professor Dickinson was the author of the relevant section of Dicey, so agreement may be expected as between the two books).

299. To fall within art.12, a non-contractual obligation between parties must have arisen in the course of an existing or contemplated contractual relationship between the relevant parties. For this reason, art.12 does not apply to the Bank’s hypothetical breach of its putative obligation of confidence when the Bank Bot Design was disclosed to the Bank at the September 2011 Meeting. I will consider below which article of Rome II applies instead.

AutoStore’s argument in relation to EVS

300. Turning to EVS, AutoStore’s argument was that confidentiality obligations which bind parties moving towards the conclusion of a contract are self-

evidently non-contractual obligations arising out of dealings prior to the conclusion of a contract. A distribution agreement was in the contemplation of AutoStore and EVS on 5 July 2010 and by the time of the September 2011 Meeting discussion of terms was under way. The parties believed that EVS and the Bank were subject to obligations of confidence. Therefore art.12 must apply to the hypothetical breaches on those dates and must apply to the exclusion of any other provision of Rome II.

EVS and the contemplation of a contract

301. As with the Bank, the question arises as to whether AutoStore and EVS contemplated a contractual relationship at the relevant times: here 5 July 2010 and at the September 2011 Meeting. With EVS, the more accurate question is whether a contract was sufficiently in contemplation.
302. More needs to be said about the notion of contemplation as proposed by Professor Dickinson and as held to be part of the law by Picken J. Commercial parties are in communication with each other all the time, at trade fairs, by way of enquiries as to what one party can offer another and so on. It could be said that at the moment of almost any such interchange, even the most brief and casual ones, the parties will share in mind the theoretical possibility of the purchase of goods or services or of some other contractual relationship. I doubt that the European legislature intended art.12 to apply to every such case. As against that, I think that art.12 must apply once a first offer has been made. But there can be an interim phase when the parties move beyond purely exploratory discussions. For instance, they may be firmly set on a contract, yet only call the lawyers in at the last minute to formulate a first offer in sufficiently clear terms such that a contract is liable to be formed if the offer is accepted. The line may be difficult to draw, but it seems to me that “dealings prior to the conclusion of a contract, regardless of whether the contract was actually concluded or not” in art.12 means dealings at a time when the parties have gone beyond casual or exploratory discussions to a point at which both believe that there is a real prospect that they will enter into a contract.
303. On the facts of the present case, no first offer had been made by 5 July 2010. It is hard to be sure based on the evidence I have heard about the meeting on 2-3 June 2010, but on balance I think it is likely that AutoStore and EVS had by 5 July 2010 gone beyond exploratory discussions about a distributorship agreement and that both believed that there was a real prospect that they would enter into such an agreement. There is no doubt that the same was true by the time of the September 2011 Meeting.

Ocado's arguments in relation to EVS

304. Ocado had several arguments. The first was that academic discussion of art.12 does not refer to the breach of an obligation of confidence.
305. The second was that EVS's obligation must be assessed as of the time it received the Bank Bot Design. This first happened upon the receipt of the July 2010 Email on 5 July 2010. At that time there was no indication that the agreement

which would later be reached between AutoStore and EVS was to be governed by Norwegian law. To decide which law applied, it would have been necessary to analyse the facts by reference to Rome I. That analysis would have led to the conclusion that Russian law applies.

306. The argument continued: it did not assist AutoStore to say (as it did) that the choice of law clause in the Distribution Agreement shone a retrospective light on the negotiations leading up to the contract. It cannot have done because that would create the nonsense of the applicable law varying over time. More than that: if Russian law leads to the conclusion that there was no obligation of confidence on 5 July 2010, AutoStore's retrospective light would be of no avail. The disclosure of the Bank Bot Design would have been made with no fetter of confidence on 5 July 2010 and that would be an end of it.
307. Ocado's third argument was based on art.6(4). Under the scheme of the Regulation, art.14 allows parties to submit non-contractual obligations to the law of their choice, in effect to opt out of many of the rules of the Regulation that would otherwise apply. However, the option is not available in relation to non-contractual obligations arising out of an act of unfair competition under art.6 (see art.6(4)). Ocado submitted that AutoStore's argument on the law would permit parties to opt out of art.6 in relation to pre-contractual negotiations by choosing a law in the contract. This would undermine the intention behind art.6(4).
308. The fourth argument was that it was unrealistic to describe the July 2010 Email as being part of the dealings prior to the conclusion of the Distribution Agreement, since the first draft of that agreement was not circulated until 23 June 2011. There was no "direct link" between the July 2010 Email and the Distribution Agreement.
309. Fifthly, AutoStore's argument was premised on there having been no *real* act of unfair competition or tort/delict by way of a breach of an obligation of confidence; it followed that arts.4 and 6 of Rome II could not apply and therefore art.12 applies. This was plainly wrong since the consequence would be that in any circumstance in which there had been no actual wrong, art.12 would always apply. This would be true even if there had been no pre-contractual discussions. AutoStore's position is therefore unworkable.
310. Sixthly, even on the most benevolent reading of the Distribution Agreement, it governed events only after 24 May 2011 (the stated time for its backdated entry into force).

Discussion in relation to EVS

311. I will consider art.12 and EVS by reference to Ocado's six arguments.
312. The first argument is noted, but it is a negative which cannot be conclusive.
313. With regard to the second, there was no evidence at all that as of 5 July 2010 it was possible to tell which law would apply to a distribution agreement of some sort in contemplation, should it be concluded. As already discussed, this must

be assessed as of 5 July 2010 because a hypothetical disclosure of the Bank Bot Design by EVS on that date which was not in breach of confidence could not become retrospectively a breach of confidence in November 2011 by reason of the parties, only then, bindingly choosing Norwegian law to govern the Distribution Agreement.

314. But it does not follow that Rome I fills the void. Art.12 remains engaged, subject to Ocado's remaining arguments. Consequently art.12(2) would apply. Neither art.12(2)(b) nor art.12(2)(c) would be engaged; but art.12(2)(a) would. I will take this further below.
315. Ocado's third argument was that notwithstanding art.6(4), parties can opt out of art.6 by choosing a law to govern the contract. In my judgment, this is premised on an incorrect view of how Rome II works. Art.12 is mandatory if the non-contractual obligation arises out of dealings prior to the conclusion of a contract within the meaning of that article. It makes no difference if breach of the non-contractual obligation can be characterised as an act of unfair competition. Like the Brussels Regulation, the provisions of Rome II are drafted to create a hierarchy. In this sense, art.12 trumps art.6.
316. Ocado's fourth argument raises this question: on the present facts, would the alleged obligation of confidence on the part of EVS have been a non-contractual obligation with a *direct* link to the contractual negotiations between EVS and AutoStore?
317. Dicey offers examples of non-contractual obligations with a direct link (see above): obligations to disclose matters relevant to the contract, not to make misrepresentations and not to apply duress. I think that the feature they have in common is that they all go to the heart of fair contractual negotiations. If I am right about that, a breach of confidence may or may not have a direct link to the relevant contractual negotiations, depending on the facts. The information disclosed in breach of confidence may have little or nothing to do with the negotiations. The breach could cause damage to the other negotiating party but have no direct effect on the fairness of the negotiations. On the other hand, the imposition of an obligation of confidence regarding the subject-matter of the negotiations may be a necessary prerequisite for the negotiations to be conducted at all. A breach of that sort of obligation would affect the fairness of the negotiations and it would follow that the obligation has a direct link.
318. In my judgment, the obligation of confidence as understood by Mr Hjorteland, Mr Konstantinov and Mr Kutsenko fell into the latter category. AutoStore was no doubt primarily interested in selling its systems to the Bank but had also contemplated some sort of distribution deal with EVS, so as to use EVS as the go-between. To move things forward AutoStore wanted to convince the Bank via EVS that "huge money" would be needed to develop new designs to meet the Bank's requirements. The Bank Bot Designs were disclosed to EVS to advance the project. The disclosure therefore had a direct link to the negotiations which included the possibility of reaching a distribution agreement.

319. I think that Ocado's characterisation of AutoStore's submission, contained in Ocado's fifth argument, was probably accurate at the start of the trial but my understanding was that AutoStore's submission evolved. Whether or not the hypothetical breach of confidence can be characterised as an act of unfair competition or as a tort (or delict), on the facts of the case the application of art.12 is mandatory.
320. The short answer to the sixth argument is that art.12 applies regardless of whether the contract was concluded at the relevant time.
321. This takes me back to art.12(2)(a) – because art.12 is engaged but it was not possible to tell at the relevant time which law would apply to the contract, were it to be concluded.

Conclusion on art.12

322. For the reasons I have given, art.12(2)(a) applies to the hypothetical breach of confidence by EVS following receipt of the July 2010 Email. The applicable law is the law of the country in which damage would hypothetically have occurred.
323. Art.12 does not apply to the putative obligation of confidence by the Bank immediately following the September 2011 Meeting because there was never any prospect of a contract between AutoStore and the Bank. In the next section of the judgment I will consider which article of Rome II applies.

Rome II and the Bank's obligation of confidence

324. In *The Racing Partnership Ltd v Done Brothers (Cash Betting) Ltd* [2020] EWCA Civ 1300, Arnold LJ said (at [46]):
- “ ... misuse of confidential information is a species of unfair competition: see article 10bis of the Paris Convention for the Protection of Industrial Property read together with article 39 of the Agreement on Trade-Related Aspects of Intellectual Property Rights (“TRIPS”) and see also recitals (2), (16), (17) and (39) and article 3(1)(d) of Parliament and Council Directive 2016/943/EU of 8 June 2016 on the protection of undisclosed know-how and business information (trade secrets) against their unlawful acquisition, use and disclosure.”
325. Lewison and Phillips LJJ disagreed with Arnold LJ as to the outcome of the appeal but not with this part of Arnold LJ's analysis.
326. In *Celgard, LLC v Shenzhen Senior Technology Material Co Ltd* [2020] EWCA Civ 1293, it was common ground that the claimant's claim of a breach of an equitable obligation of confidence by the defendant's exploitation of confidential information relating to battery separators arose out of an act of unfair competition within the meaning of art.6 of Rome II. It was also agreed by the parties that the claim concerned an act of unfair competition affecting exclusively the interests of a specific competitor within the meaning of art.6(2), namely the claimant, and that therefore art.4 of the Regulation applied.

Consequently, the applicable law was the law of the country in which the damage had occurred.

327. Although it was assumed in *Celgard* that art.6(2) was engaged, on the present facts it is not self-evident. AutoStore argued that it would not be because, unlike the facts of *Celgard*, the Bank was not a specific competitor of AutoStore. This assumes that art.6(2) requires that the party alleging the act of unfair competition must be a specific competitor of the party alleged to have committed the act. That is not expressly stated by art.6(2) but I find it difficult to make sense of art.6(2) if it is not implied.

328. Cheshire, North and Fawcett, *Private International Law*, 15th ed., says this (omitting footnotes):

“**Article 6(2)** The second choice of law rule is concerned with where ‘an act of unfair competition affects exclusively the interests of a specific competitor’ (Article 6(2)). In other words, a specific competitor is targeted. This would, for example, encompass enticing away a competitor’s staff, corruption, industrial espionage, disclosure of business secrets or inducing [a] breach of contract. As the word, ‘exclusively’ makes clear, Article 6(2) does not apply to acts of unfair competition such as passing-off or misleading advertisement which, while targeting a specific competitor, also affect the market as a whole, in particular the decisions of the other side of the market.”

329. Dicey (16th ed. at 35-062) states that it may be helpful to ask:

“... whether the act of unfair competition gives a competitive advantage to the defendant at the expense of a single competitor, without at the same time materially changing the conditions of competition in the market as a whole.”

330. The distinction being drawn by the authors of Cheshire and Dicey is between an act of unfair competition which exclusively affects one party’s business, a competitor, as opposed to one which additionally changes the condition of the relevant market.

331. Cheshire expressly cites the disclosure of business secrets as an example of the former category, an example taken from the Commission’s Explanatory Memorandum published during the drafting of Rome II. However, I am not sure that torts can be neatly sorted into one category or another so that art.6(2) applies or does not apply depending solely on the nature of the tort.

332. Cheshire cites passing off as an example of a tort to which art.6(2) does not apply because the commission of the tort affects the market as a whole, in particular the decisions of the other side of the market, typically customers. On the other hand in *Lyle & Scott Ltd v American Eagle Outfitters Inc* [2021] EWHC 90 (Ch) the claimant and defendant were both high-end clothing brands based in the United States, both using the image of a flying eagle as a logo. The defendant applied to set aside an order of the Master giving permission to serve

the claim for passing off and breach of contract on the defendant in Pennsylvania. One issue was the identity of the law governing the allegation of passing off. Miles J held that this was determined by art.6 of Rome II, which led to whether art.6(2) was engaged:

“[73] The next question is whether the claim falls within art.6(2). In my view it does. The act of unfair competition alleged (passing off) affects exclusively the interests of a specific competitor ([the claimant]). It follows that art.4 applies.”

333. I find it difficult to distinguish a typical case of passing off from a typical instance of industrial breach of confidence with regard to the likely impact on the market and the decisions of customers in the market. When a defendant commits an act of passing off, representing its goods to be the claimant's goods or to be otherwise connected with the claimant, thus inducing customers to buy from the defendant, it could be said that the market is thereby changed because the defendant is enabled to enter the market in a manner which will affect customer decisions. A breach of confidence by a defendant could just as much affect the condition of the market. It could enable the defendant, and indeed any third parties to which the defendant passes the relevant information, to make products using that information and thereby to enter the market, again affecting the decisions of customers in that market. In the case of passing off, the customers are the victims of a misrepresentation, in the breach of confidence example they are not. But this is not relevant to the distinction addressed by art.6(2).
334. I have therefore reached the view that the question whether a breach of confidence engages art.6(2) is fact dependent, as opposed to depending on the nature of the tort.
335. The present hypothesis is that the Bank was under a general obligation not to disclose the Bank Bot Designs, as discussed above. Such an act would have enabled AutoStore's competitors to compete in a more effective way in the market for automated warehousing systems (a) because AutoStore's ability to obtain patents worldwide would have been restricted and (b) the information conveyed by the Bank Bot Designs could have been used anywhere. The conditions of competition in the market would be changed as would be, potentially, decisions of customers in the market. In my view, for that reason and because the Bank is not a competitor of AutoStore's, art.6(2) is not engaged.
336. It follows that, pursuant to art.6(1), the law applicable to a putative obligation of confidence on the Bank was the law of the country where competitive relations or the collective interests of consumers are, or are likely to be, affected.

The relevant law or laws under art.6(1)

337. Recital [21] of Rome II states:

“The special rule in Article 6 is not an exception to the general rule in Article 4(1) but rather a clarification of it. In matters of unfair

competition, the conflict-of-law rule should protect competitors, consumers and the general public and ensure that the market economy functions properly. The connection to the law of the country where competitive relations or the collective interests of consumers are, or are likely to be, affected generally satisfies these objectives.”

338. The CJEU commented on the relationship between art.4 and art.6(1) in *Verein für Konsumenteninformation v Amazon EU Sàrl* (C-191/15) EU:C:2016:612:

“[41] It follows from recital (21) to the Rome II Regulation that article 6(1) expresses, in the specific field of unfair competition, the *lex loci damni* principle laid down in article 4(1) of the Regulation.”

339. Thus, when applying art.6(1) the same overall principle must be adopted as in art.4(1), looking for the place where the damage occurred, with a steer as to where that will be in a case of unfair competition. It may often be that the analysis under art.4(1) leads to the same result as that under art.6(1).

340. In *Verein für Konsumenteninformation v Volkswagen AG* (C-343/19) EU:C:2020:534, the CJEU was asked to consider art.7(2) of the Brussels Regulation (recast) (Regulation (EU) No. 1215/2012) which provides, so far as is relevant:

“*A person domiciled in a member state may be sued in another member state: ... (2) in matters relating to tort, delict or quasi-delict, in the courts for the place where the harmful event occurred or may occur ...*”

341. The case concerned the sale of VW cars in Austria. VW had equipped them with software which caused the impression that they emitted pollutants at a level much lower than was the case in real driving conditions. The claimant, an Austrian consumer association, brought an action on behalf of purchasers alleging that the value of the cars was accordingly 30% below the sale price. The reference from the Austrian court concerned whether Austria was the place in which the harmful event occurred, so that art.7(2) conferred jurisdiction on the Austrian courts. The court pointed (at [26]-[28]) to the well-established case law that only direct harm, i.e. harm suffered by persons who were the direct victims of damage, was relevant. In this instance it was the difference between the price paid by purchasers of the vehicles and their real value:

“[35] It must therefore be concluded that, where vehicles equipped by their manufacturer with software that manipulates data relating to exhaust gas emissions are sold, the damage suffered by the final purchaser is neither indirect nor purely financial and occurs when such a vehicle is purchased from a third party.”

342. The Court added:

“[39] Lastly, that interpretation satisfies the requirement of consistency laid down in recital (7) of the Rome II Regulation, in so far as, in accordance with article 6(1) thereof, the place where the damage occurs in a case involving an act of unfair competition is the place where

‘competitive relations or the collective interests of consumers are, or are likely to be, affected’. An act, such as that at issue in the main proceedings, which, by being likely to affect the collective interests of consumers as a group, constitutes an act of unfair competition (*Verein für Konsumenteninformation v Amazon EU Sàrl* (Case C-191/15), para 42), may affect those interests in any member state within the territory of which the defective product is purchased by consumers. Thus, under the Rome II Regulation, the place where the damage occurs is the place in which such a product is purchased (see, by analogy, *Tibor-Trans*, para 35).”

343. A distinction which the Court drew was between the cause of the damage, presumably the installation of the software, and the direct damage itself, the payments made for cars at a price above their market value. Drawing an analogy with the present case, it seems to me that the hypothetical cause of damage to AutoStore would have been the disclosure of the Bank Bot Design; the direct damage would have been the restriction on AutoStore’s ability to patent warehouse robots and automated storage systems, and increased competition in the markets for those products.
344. Before turning to the consequence of that, I must deal with another submission made. This was from Ocado in the context of its argument on art.4(1). Ocado said that *Celgard* (cited above) was authority for the proposition that in a case of alleged misuse of confidential information, the damage occurs in the place where the confidence is breached. If that were correct it would presumably apply equally to art.6(1), but I do not accept that the argument is correct.
345. In *Celgard* a former employee of the US claimant was alleged to have passed trade secrets to the Chinese defendant, apparently in China but certainly not in the UK. At first instance the judge had held that the direct damage caused by the breach of confidence was in the UK because it was the UK market that was damaged by the importation of products which had been made in China by exploiting confidential information. Arnold LJ (at [55]-[64]), with whom Popplewell and Davis LJJ agreed, endorsed the judge’s view. Arnold LJ’s judgment included this:

“[64] Seventhly, as counsel for Celgard pointed out, the effect of Senior’s argument is that, where party A based in country X, which has weak trade secrets protection, misuses party B’s trade secrets to manufacture goods, and then puts the goods on the market in an EU country, the law of country X would apply to the exclusion of the law of the EU country. As counsel for Celgard submitted, this is an improbable result given that the Trade Secrets Directive is designed to strengthen protection against misuse of trade secrets ‘whether from within or from outside the Union’ (recital (4)) and that it explicitly contemplates that measures should be granted which include ‘the prohibition of the importation of [infringing] goods into the Union’ (recital (28)). Admittedly, the Rome II Regulation and the Trade Secrets Directive are different pieces of legislation, but it seems unlikely that one should be

interpreted in a way that undermines the objectives of the other unless this is mandated by the wording, which is not the case.”

346. It follows from the foregoing that the law to be applied to the putative obligation of confidence on the Bank is that of the country or countries in which AutoStore has a market that would be damaged by the hypothetical breach and that of the countries in which AutoStore’s ability to patent its technology would have been restricted. This potentially presents a wide range of laws made available under art.6(1).

347. Arnold LJ’s judgment in *Celgard* included this:

“[61] Fourthly, although counsel for Senior argued that it was desirable to locate the direct damage caused by misuse of confidential information in a single country, that is contrary to the approach laid down by both art.4 and art.6. This was the legislative intention: the European Commission’s Explanatory Memorandum accompanying the proposal for the Rome II Regulation stated at p.11 that the rule in what is now art.4(1)

‘entails, where damage is sustained in several countries, that the laws of all the countries concerned will have to be applied on a distributive basis, applying what is known as “Mosaikbetrachtung” in German law’ .

Similarly, it stated at p.16 what is now art.6 ‘provides for connection to the law of ... the market where competitors are seeking to gain the customer’s favour’. It went on to state that it was important that ‘only the direct substantial effects of an act of unfair competition’ should be taken into account in international situations ‘since anti-competitive conduct commonly has impact on several markets and gives rise to the distributive application of the laws involved’.”

348. Counsel made no submissions on the correct application of *Mosaikbetrachtung* (mosaic approach) beyond this doctrine leading to the potential for a succession of actions for infringement in those countries in which there has been substantial direct damage, in each case with the law of the relevant country governing the issue of confidentiality.

349. Dicey (at 35-028), in the context of art.4, refers to the Explanatory Memorandum and the endorsement of *Mosaikbetrachtung* by the Court of Appeal in *Celgard*. The authors continue:

“This may be one point where principle may ultimately yield to pragmatism, particularly in cases (such as a claim for non-monetary remedies) where the fragmented application of the laws of several countries may be impossible or exceedingly difficult. In such cases, the temptation may be to avoid this theoretical difficulty by seeking to locate the ‘direct’ damage in a single country or by making use of the ‘escape clause’ in Art.4(3) of the Regulation.”

350. Unfortunately, art.6 has no escape clause equivalent to art.4(3). I must apply art.6(1) as it is and follow the principle of *Mozaikbetrachtung* impliedly approved by the Court of Appeal.
351. Although the laws of numerous countries are potentially made applicable by art.6(1), I think that attention must be paid to the hypothesis posited in this case. It is that the Bank was about to make Bank Bot Designs public or had already done so.
352. In the first alternative, AutoStore's priority would have been to prevent any disclosure happening before the free availability of the designs became a *fait accompli*. AutoStore's only real option would have been to seek relief in Russia because that is where the Bank is domiciled.
353. If the Bank had already made the Bank Bot Designs public, the jurisdiction of courts outside Russia may have been available, depending on where the disclosure was made. *Mosaikbetrachtung* would have permitted the application of the local law to the issue of confidentiality, based on direct damage in the local jurisdiction. There is neither room nor information for a review of whether, in any particular country, the jurisdiction of the court would have been confined to acts done in that country and/or damage suffered in that country. The short point is that the most effective remedy would very likely have been that which could be afforded by a Russian court on the necessary further hypothesis that the Russian court would have heard AutoStore's claim.
354. Of the laws made applicable under art.6(1) of Rome II to apply to the question of confidentiality, the one that would have mattered on the hypothesis raised would have been Russian law.
355. This is not the same thing as considering what a Russian court would have done in the event of a real claim against the Bank. This is an action before an English court. The issue of confidentiality which has arisen within the action falls to be decided by this court applying its own choice of law rules, here Rome II, to assess which law is to be applied to the facts in order to resolve whether the Bank was subject to an obligation of confidence at the relevant time. Questions raised at the trial, such as which law a Russian court would have applied, are not relevant to anything I have to decide, see art.24 of Rome II.

The relevant law under art.12(2)(a)

356. The law to be applied under art.12(2)(a) is the same as that which would be applied under art.4(1). On the facts of this case, it does not differ from that applicable under art.6(1). The damage from EVS's breach would have been a restriction on its ability to acquire patent protection in all the jurisdictions of interest to AutoStore and increased competition in all the territories in which AutoStore markets its systems. *Mozaikbetrachtung* and the most important law on the hypothetical facts come into play. The applicable law is Russian law.

Russian law

357. I would begin by saying that given the unambiguous evidence that AutoStore, the Bank and EVS all clearly understood that the Bank and EVS were under an obligation of confidence with regard to the Bank Bot Designs and given the nature of that information, had this been an issue to be resolved under English law, in my judgment the receipt of that information by the Bank and EVS, both in the July 2010 Email and in the September 2011 Meeting, would have been under an equitable obligation of confidence; what the EPO calls a tacit agreement.
358. However, it is Russian law that matters. As I will explain, the existence of an obligation of confidence under Russian law depended largely (or wholly, according to Ocado) on whether the parties had entered into an express contract of confidentiality. In closing, counsel submitted that AutoStore did not assert that there was such a contract under Russian law. This caused a small flurry. Counsel clarified. The clarification was not completely unambiguous, but if I understand correctly, AutoStore's position is that its primary submission rests on art.12 of Rome II, not on any contract (which really required no clarification); if that argument were to be rejected, then AutoStore's backup position is, among other things, that there was a contract of confidentiality under Russian law. I must therefore consider the backup.

The evidence

359. Professor Maggs and Mr Kulkov agreed that at the relevant time there were two principal ways in which Russian law protected confidential information. The first was by establishing a commercial secrecy regime under art.1465 of the Russian Civil Code ("RCC"). The second was by a contract of confidentiality under art.421 RCC. Professor Maggs suggested that there were other routes as well, which I will come back to.
360. AutoStore could not have protected its disclosures in the present case under the Commercial Secrecy provisions of art.1465 RCC because, as was common ground, there had been no compliance with the requirements of that regime.
361. Mr Kulkov suggested in a later part of his report that the Commercial Secrecy provisions had to be complied with even in respect of a contract of confidentiality under art.421 RCC. In an earlier section I did not understand him to be saying that. The position is complicated by the fact that in other proceedings Professor Maggs gave evidence that the Law of Commercial Secrecy does indeed impose overriding and mandatory provisions on contracts of confidentiality (see my discussion above on Professor Maggs as a witness). I am unable to reach a clear view about this.
362. Assuming that a contract of confidentiality under art.421 does not have to comply with the Law of Commercial Secrecy, I turn to other, more basic requirements. Like English law, the creation of a contract under Russian law requires an offer and an acceptance. An offer is defined by art.435 RCC:

"Article 435

1. *An offer is a proposal addressed to one or several specific persons, that is sufficiently definite and expresses the intent of the person who has made the proposal to consider himself having concluded a contract with the addressee by whom the proposal will be accepted. The offer must contain the essential terms of the contract.*

2. *The offer binds the person who sent it from the moment it is received by the addressee. If a notice of revocation of the offer was received earlier or simultaneously with the offer itself, the offer is considered not received.”*

363. Art.438(2) RCC addresses acceptance:

“1. Acceptance is the response of the person to whom the offer is addressed regarding its acceptance. The acceptance must be complete and unconditional.

2. Silence does not constitute acceptance, unless otherwise follows from the law, business customs or from the previous business relationship of the parties.

3. The performance by the person who received the offer, within the time period established for its acceptance, of actions to fulfil the terms of the contract specified in it (shipment of goods, provision of services, performance of work, payment of the corresponding amount, etc.) is considered acceptance, unless otherwise provided by law, other legal acts or is not specified in the offer.”

364. Professor Maggs relied on the principle set out in art. 438(2) that silence may constitute acceptance if based on law, business customs or from the previous business relationship of the parties.

365. The experts agreed that a contract between commercial entities must be in a “simple written form”. Art.162(1) RCC provides:

“Non-observance of the simple written form of a transaction shall deprive parties of the right, in case of a dispute, to rely for confirmation of the transaction and its terms upon the testimony of witnesses, but shall not deprive them of the right to adduce written and other evidence.”

366. Further, at the relevant time art.163(2) RCC was in force:

“Non-observance of the simple written form of a foreign economic transaction shall entail the invalidity of the transaction.”

367. Professor Maggs did not say that there is a general doctrine of implied terms in a contract under Russian law or if so, how it works. Mr Kulkov said that there was no such general doctrine. However, Professor Maggs referred to art. 421(5) RCC which provides that gaps in a contract may be filled by “customs of commerce”. He relied on a case, *Tisma v Inspectorate of the Federal Tax Service*, in which the court upheld the binding effect of a custom of

confidentiality as a basis for the claimant's refusal to disclose certain information about its contract partners to Russian Customs. He quoted this passage:

“If one agrees with the stated position of the tax body, then Open Joint-Stock Company Tisma, in concluding a contract of sale of its goods with a buyer must inform it about with whose assistance Tisma was able to conduct such actions, which does not correspond to the customs and rules of commerce. On the contrary, commercial entities try, as a rule not to disclose the measures taken (conduct of marketing research of the market, search for buyers, preparation of the necessary documentation) preceding the conclusion of a contract with another party so as to maintain its business reputation.”

368. Professor Maggs' overall suggestion was that the July 2010 Email and the September 2011 Meeting would each have given rise to enforceable contracts. Gaps in those contracts could have been filled by the use of “customs of commerce” and in this instance would have introduced an obligation of confidence.
369. Mr Kulkov's evidence was that in order for a confidentiality agreement to be properly concluded, the agreement had to state expressly the following:
- (i) the scope of the confidential information;
 - (ii) the parties' obligation not to disclose the confidential information; and
 - (iii) the time period for the obligation of the parties.
370. He agreed with Professor Maggs that under art.421(5) RCC business customs applicable to the relations of the parties could determine a term which fills a gap in the express terms of a contract where, without the relevant business custom, the agreement cannot function. However, he also made the following points. Under art.5(2) RCC, business customs cannot be applied if they contradict the provisions of legislation. Secondly, art.421(5) can only be applied to fill a gap in a concluded agreement. Business customs cannot be relied on to create standalone obligations. These points seemed not to be in dispute.
371. Moving on from contracts, Professor Maggs had three further routes to the imposition of such an obligation of confidence under Russian law. Mr Kulkov's view was that none of them was sound in law.
372. The first was that AutoStore might plead its claim to confidentiality as an “abuse of right” under art.10 RCC which provides in relevant part:
- “... actions of citizens and legal persons taken exclusively with the intention to cause harm to another person are not allowed, nor is the abuse of a legal right allowed in other forms.”
373. On the face of the article, the scope of acts taken exclusively with the intention to cause harm may be limited. Professor Maggs and Mr Kulkov agreed that the

most analogous situation in which art.10 has been held to apply is where a shareholder exercised his right to certain types of information from the company in order to harm the company, such as using it in a business in competition with the company. Mr Kulkov said that the application of art.10 in a commercial context was narrow, confined to the shareholder example. Professor Maggs argued that it was wider. He referred to an academic commentary and quoted from a translation of a judgment of the Russian Constitutional Court in *On the Complaint of OJSC Rosneft Oil Company about the Violation of Constitutional Rights and Freedoms*, 18 January 2011, N 8-OP.

374. Professor Maggs' second alternative route was that a Russian court may have characterised a claim for confidentiality relating to the July 2010 Email as a breach of pre-contractual obligations. The pre-contractual obligation relied on was not one of Russian law, but Norwegian law. Professor Maggs asserted that a Russian court would recognise a Norwegian law of pre-contractual obligations. Parts of the RCC dealing with Russian conflict of laws were cited, but the analysis was brief and no example of their application in any context was provided.
375. The third was that had the Russian court treated the alleged breach of confidence in July 2010 as an alleged tort, arts. 1219 and 1220 RCC would apply. Art. 1219 provides:

“1. The law of the country where the action or other circumstance took place that served as the basis for the claim for compensation for harm shall be applied to obligations arising as the result of causing harm. In the case when, as the result of such an action or other circumstance, the harm occurred in another country, the law of that country may be applied if the one who caused the harm foresaw or should have foreseen the occurrence of harm in that country.

2. If the parties are citizens or legal persons of one and the same country, the law of that country shall be applied to obligations arising as the result of causing harm abroad. In the case when the parties to such an obligation are not citizens of one and the same country, but have their place of residence in one and the same country, the law of that country shall be applied.

3. After the taking of the action or the occurrence of another circumstance entailing the causing of harm, the parties may agree on the application to the obligation that arose as the result of causing harm of the law of the country of the court.”

376. This is art. 1220:

“The following shall be determined, in particular, on the basis of the law applicable to obligations arising as the result of causing harm:

- 1) the capacity of a person to bear liability for harm caused;*

- 2) *the imposition of liability for harm upon a person who was not the one who caused harm;*
- 3) *the bases of liability;*
- 4) *the bases of limitation of liability and for freeing from it;*
- 5) *the means of compensation for harm;*
- 6) *the scope and amount of compensation for harm.”*

377. Professor Maggs suggested that arts. 1219 and 1220, particularly the second sentence of art. 1219(1), point to the application of Norwegian law.
378. Finally, Mr Kulkov addressed which individuals had the power to enter into a contract on behalf of a company. He said that the company’s “constituent documents” would state who had such power. This would normally be the CEO, but it could also be a person given power of attorney under the signature of the CEO. No other persons have the power to bind a company.

Discussion

379. The principal point of dispute was whether a contract of confidentiality could have been concluded under Russian law on the facts of this case. If it was a contract of confidentiality, there will have been no need for customs of commerce to fill out its terms to impose on EVS and the Bank an obligation of confidence. I accept Mr Kulkov’s evidence that customs of commerce could not by themselves create a standalone obligation of confidence.
380. I will begin with the July 2010 Email. The only candidate for an offer advanced by AutoStore was the July 2010 Email itself. It does not on its face contain an offer. Professor Maggs was reduced in cross-examination to saying that it was a question of interpreting the intent of the parties from the words of the email and was a matter for the court. In my view nothing in the words could accurately be interpreted as an offer. In the email Mr Hjorteland explained proposed design developments, attached drawings and stated what was included in the development cost. That was it. Mr Kutsenko said expressly in cross-examination that in his view the July 2010 Email did not contain an offer under Russian law. In his cross-examination Mr Hjorteland appeared not to understand the idea that the July 2010 email contained an offer and said that there was no contract between the parties in 2010.
381. Art. 435(1) RCC requires an offer to contain the essential terms of the contract, which I take to mean the essential terms being proposed by the offeror. No such terms are contained in the July 2010 Email.
382. In my judgment, the July 2010 Email did not constitute an offer. Because it is not possible to construe an offer out of the July 2010 Email, it is equally not possible to say how silence could have constituted an acceptance of anything. There was certainly no email from EVS constituting an acceptance under art.438(1) RCC.

383. Mr Konstantinov's evidence was that only Mr Lebedev had authority to enter into a contract on behalf of EVS. Therefore no email from Mr Kutsenko could have constituted an acceptance. AutoStore suggested that EVS acted as an agent for the Bank. There was no evidence filed to support an agency agreement. In any event, if Mr Kutsenko could not bind EVS, he could never have bound the Bank to the terms of any contract.
384. Finally, there was no candidate for a document which set out the alleged contract "in simple written form".
385. As Mr Hjorteland said, there was no contract in 2010.
386. Since there was no contract, there was no contractual obligation of confidence binding either EVS or the Bank under Russian law with respect to any information disclosed in the July 2010 Email.
387. I note in passing that Professor Maggs suggested in cross-examination that the general disclaimer at the end of the email would imply that the offeror was intending an agreement as to confidentiality. In my view, had there been a contract, it would require a standard email disclaimer to do much more work than any reasonable offeree would have understood for it to act as a term binding EVS or the Bank.
388. Without a contract, there can have been no term implied by custom under art. 421(5) RCC. I was anyway not able to gain much from the evidence regarding the *Tisma* case save that commercial entities in Russia tend to safeguard their reputation by providing limited information to the other side in contractual negotiations.
389. That leaves three additional routes to an obligation of confidence under Russian law proposed by Professor Maggs, all disputed by Mr Kulkov.
390. I have read the commentary on "abuse of right" under art. 10 RCC and the extract from the judgment in *Rosneft* provided by Professor Maggs. I read neither as supporting a wide reading of art.10 RCC such that it would apply to the disclosure of confidential information. Its application may or may not be as narrow as Mr Kulkov states, but I do not accept Professor Maggs' evidence on this. In fact, in the end he was only able to say that its application to a breach of confidence was "at least a colourable argument". Mr Kulkov described it as "no more than speculation". I was left with the impression that I was being invited by Professor Maggs to interpret Russian law in an interesting and radical manner, an invitation which I decline.
391. Regarding pre-contractual negotiations, this was derived from Professor Maggs' proposal – I think it is fair to say speculation – about a possible application of Russian principles of the conflict of laws. These are irrelevant, see art.24 Rome II. I would anyway have needed less speculative evidence with concrete instances of how Russian courts approach foreign pre-contractual obligations to find this characterisation of Russian law likely.

392. Professor Maggs had a final point on Russia's conflicts of laws, in particular arts.1219 and 1220 RCC. Again, these are irrelevant, see art. 24 of Rome II. Even if they were not, the first sentence of art.1219 RCC seems to me to point to the application of Russian law. The application of the law of the country in which the harm occurred, under the second sentence on which Professor Maggs' placed reliance, appears to be an optional alternative. I was given no reason why a Russian court would reject the first sentence and apply the second. Even if it did, for reasons I have discussed above, harm under the second sentence would be threatened in a large number of places, including Russia. I think it is likely that even this route would have led a Russian court to the application of Russian law.
393. For the foregoing reasons, I conclude that the information disclosed to EVS in the July 2010 Email was imparted without any obligation of confidence binding EVS under Russian law.
394. That being so, the position with regard to the September 2011 Meeting is academic and I will take it briefly. There was no evidence to support the reaching of an oral contract at that meeting. I was not given any idea what the offer might have been, by whom it was made, how acceptance was communicated and by whom that was done. No document was produced in "simple written form" containing the "essential terms of the contract".
395. Mr Konstantinov said in cross-examination that he did not believe there was any confidentiality agreement between EVS and AutoStore at the September 2011 Meeting. Mr Hjorteland said that there was no contract at all until the Distribution Agreement between AutoStore and EVS dated 18 November 2011. They were both right. There was no contractual obligation of confidence at the September 2011 Meeting. Despite what the participants thought, there was no obligation of confidence of any kind in law.

Conclusion on the Bank Bot Information

396. The Bank Bot Information was disclosed by AutoStore in both the July 2010 Email and at the September 2011 Meeting without imposing any obligation of confidence on either EVS or the Bank.
397. It follows that EP 794 lacks novelty and EP 027 either lacks novelty or inventive step.

Ten Hompel and Inventive step

398. Only one item of prior art was cited in support of Ocado's case on lack of inventive step in relation to both EP 794 and EP 027: German Patent Application DE 10 2009 017 241 A1 ("ten Hompel").

The law

399. There was no dispute about the law. Inventive step is to be assessed by reference to the steps set out in *Pozzoli SpA v BDMO SA* [2007] EWCA Civ 588, at [23]. The skilled person and the CGK of step 1 have been discussed above. It is not

necessary to consider the inventive concept of step 2. Like the parties I will give primary attention to the key steps 3 and 4 by reference to the content of the relevant claims.

400. Before doing that, one point merits consideration. The system disclosed in Ten Hompel was never put into effect as a commercial storage system. Professor Limebeer was dismissive of it in cross-examination, calling it an unsatisfactory piece of work, lacking in detail. He also said this in his first report:

“Overall, my view is that the Skilled Engineer would consider Ten Hompel as simply propagating conventional aisle-based thinking whilst introducing additional unresolved challenges. Ten Hompel does not provide any obvious advantages that would make it worth trying to meet these challenges. Accordingly, I believe that Skilled Engineer would not be motivated to take it further.”

401. This led AutoStore to develop an argument along the same lines in some detail and to submit:

“All of this means Ten Hompel is an unattractive starting point – which explains why nobody in real life ever did anything with it.”

402. In *Eli Lilly & Co v Human Genome Sciences Inc.* [2008] EWHC 1903 (Pat), Kitchin J (as he was then) said:

“I accept that the skilled person must be deemed to consider any piece of prior art properly and in that sense with interest. This emerges clearly from the decision of the Court of Appeal in *Asahi Medical Co Ltd v Macopharma (UK) Ltd* [2002] EWCA Civ 466 and is necessary to prevent a patent from depriving the public of their right [to] make or do anything which is merely an obvious modification of what has been done or published before. But the law does not deem the skilled person to assume the prior art has any relevance to the problem he is addressing or require him to take it forward. Having considered it, he may conclude that it is simply not a worthwhile starting point and so put it to one side.”

403. Giving particular attention to the words “starting point”, as AutoStore has done, can lead away from what, in my view, Kitchin J had in mind. As Kitchin J said, the skilled person must be deemed to consider every cited item of prior art with interest, in the sense of giving it diligent consideration. It is not part of the hypothesis in law that the skilled person begins their consideration by assessing the merits of the prior art as a starting point. The skilled person may often be aware of a technical problem in the art, but he or she knows nothing about the invention and therefore cannot know how interesting the prior art may be as a starting point on the road to that invention. It is just a piece of prior art. In reviewing what the skilled person would make of it, I think that it is better to focus solely on what the prior art discloses and what it does not disclose, rather than gauging its interest to the skilled person. Having diligently considered a piece of cited prior art in its entirety at the relevant date, as must be done in

every case, the skilled person either contemplates a variation on it which is the invention, or they do not. In the latter case, they put it to one side.

The disclosure in ten Hompel

404. Ten Hompel discloses a storage system said to be an improvement over the prior art, where access to storage units is achieved by service devices (forklifts for instance) which move in lanes between rows of shelves. The specification notes that typically only one service device can operate in any one lane; there have been solutions allowing multiple service devices to move in one lane but the common feature of all such solutions is that direct, unobstructed access to each storage unit is limited.

405. The specification continues:

“[0004] In order to solve this problem, the goal of the invention is to create a solution, which allows for extremely flexible storage and distribution of goods and the use of shuttle vehicles, which, in particular, can reach practically every storage point independently from each other.

[0005] ... this task is solved, according to the invention, by equipping the storage with storage positions arranged in horizontal planes that can be acted on via the horizontal service planes with vertical access of service devices.”

406. The experts described this idea as the traditional arrangement of vertical aisles between shelves tilted by 90°, so that the aisles are horizontal rather than vertical. This is figure 1:

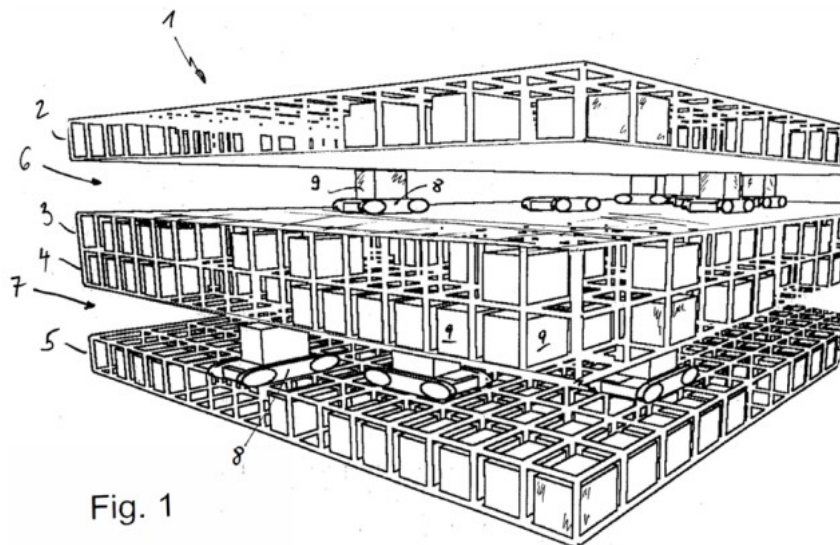

Fig. 1

407. The service vehicles 8 move in the horizontal aisles 6 and 7, either lifting or lowering storage containers 9 into storage positions 10, as shown in figure 2:

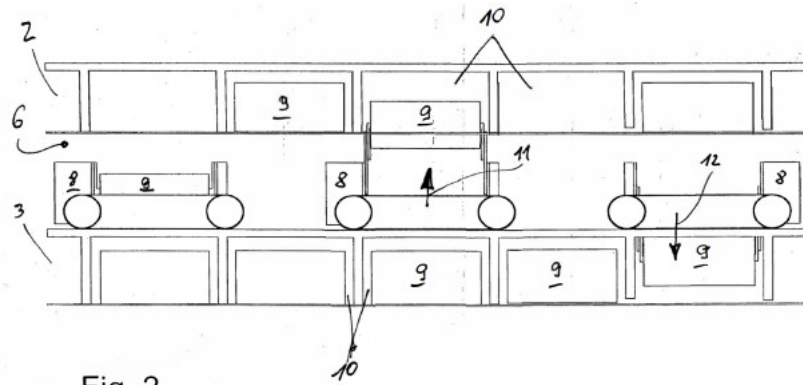

Fig. 2

408. The advantage is better access:

“[0006] A particular recognizable benefit of this invention lies in the way the shelf service technology accesses storage units. Instead of a line-by-line arrangement of storage compartments (single- or multi-level in depth) with the respective storage and retrieval from the side (the shelf front), the storage compartments are arranged by levels, and the access to storage units takes place from above or from below or from above and below.”

409. The specification gives further detail:

“[0008] The invention also provides that the storage positions in the ceiling plane are equipped with semiautomatic or automatic locking and unlocking devices for storage units that need to be placed in storage, such as palettes, containers or the like, wherein, for example, as already known from other storage solutions, a further embodiment of the invention is storing units in multiple layers above each other in one storage position.

[0009] Depending upon the structure and design of the storage system according to the invention, the service devices may be driving along the rails located in the horizontal plane in length and width directions, wherein, as already provided by the invention, a different option according to the invention is that the service vehicles are freely propelled by chain drive or the like in the horizontal plane between the storage planes.”

410. Professor Fottner acknowledged that the “semiautomatic or automatic locking and unlocking devices” referred to in paragraph [0008] were a technical complication. Self-evidently, a locking device would be required where a storage unit is either lifted into storage in the ceiling plane, some sort of latch mechanism to keep the unit from falling back down. The latch must be released when a unit is withdrawn from overhead storage.

411. Ocado submitted that the complication could be avoided by limiting storage to positions in the floor plane below the service device. It seems to me that

paragraph [0006] informs the reader that this is an option. Paragraph [0007] likewise:

“[0007] ... Embodiments may provide that the storage system has at least one level of storage positions in the floor plane and/or at least one level of storage positions in the ceiling plane, wherein service vehicles can drive between the floor and ceiling planes.”

412. The disadvantage would apparently be a potential halving in storage density. Paragraph [0004] promises that the shuttle vehicles “can reach practically every storage point independently of each other.” If storage positions are accessed only from above, this implies one horizontal aisle for every storage plane. Paragraph [0008] discloses a means of mitigating the loss in storage density: the latching system for storage in the ceiling plane can be used to allow for containers to be arranged vertically above each other.

413. The specification does not expressly state that the storage containers are “stacked”, in the sense of being in a self-supporting pile, each container in contact with one above and/or below – as opposed to an arrangement of vertically successive latches, each supporting a container. Ocado argued that the description of “multiple layers above each other” in paragraph [0008] as being “as already known from other storage solutions” must be a reference to stacking. Although paragraph [0008] discusses this overall in the context of latches, I was not shown a prior art system of vertically successive latches, so Ocado was probably right about this.

414. Rail mounted shuttle vehicles (called alternatively “service devices” or “service vehicles”) are an option:

“[0009] Depending upon the structure and design of the storage system according to the invention, the service devices may be driving along the rails located in the horizontal plane in length and width directions, wherein, as already provided by the invention, a different option according to the invention is that the service vehicles are freely propelled by chain drive or the like in the horizontal plane between the storage planes.”

415. The principal advantage of the ten Hoppel system is that because the ‘aisles’ are horizontal, the forklifts or other shuttle vehicles can manoeuvre around each other in a single aisle. This allows for “extremely flexible storage” and access to “practically every storage point”. The flexibility and ease of access would be compromised, though, by having to access a storage unit located somewhere in a vertical arrangement.

416. Professor Limebeer had a low opinion of ten Hoppel and its value to a skilled person. Certainly, there is no explanation as to how the multiple layers of storage planes with horizontal aisles between each layer are to be supported. How vertically successive latches would work is not explained. It was common ground that nothing like ten Hoppel has ever been implemented.

417. Professor Fottner's evidence was that a skilled person reading ten Hompel would think of selections within ten Hompel and changes to it that would lead to the invention of claim 1 of EP 794. In summary they are:
- (1) Abandoning the idea of storage above the vehicle and storing only below the vehicle using a lifting device connected to the vehicle body.
 - (2) Choosing to stack the units vertically on top of each other.
 - (3) Having two sets of wheels in the vehicle, arranged to be perpendicular to one another.
 - (4) Having one set of wheels arranged fully within the vehicle body.
 - (5) Having a section for receiving the storage bin being a centrally arranged cavity within the vehicle.
418. Professor Fottner stated in cross-examination that the advantages (and by implication the structural features) of claim 1 of EP 794 occurred to him as modifications to ten Hompel before he saw EP 794. Professor Limebeer in cross-examination stated that to go from ten Hompel to claim 1 of EP 794 would require the stitching together of "a whole lot of disparate things".
419. I find Professor Limebeer's evidence on this much more persuasive than that of Professor Fottner. Points (1) and (2) require selections among the possibilities disclosed in ten Hompel and would be adopted only if the skilled person were to contemplate changes which would compromise ten Hompel's promise of flexibility and accessibility.
420. Professors Fottner and Limebeer attached little inventive significance to point (3) with the important proviso that the skilled person has made another selection, to mount the shuttle vehicle on to rails rather than using the more flexible arrangement of free moving vehicles as shown in figures 1 and 2.
421. Ocado argued that point (4), having one set of wheels arranged fully within the vehicle body, was obvious. Professor Fottner said that at least one set of wheels would need to be capable of being lifted and lowered so that each set of wheels could be alternately placed on the rails, allowing the vehicle to be driven in both length and width directions. I accept this evidence, although on the assumption that the rail option is chosen. This proposition and figure 2 of ten Hompel were put to Professor Limebeer in cross-examination. Professor Limebeer said that it did not follow that one set of wheels must be fully within the vehicle body. I agree with Professor Limebeer on this.
422. There is no hint anywhere in ten Hompel of point (5).
423. In my view, it may be that any one of points (1) to (3) would have been individually obvious to a skilled person reading ten Hompel in December 2012. But they are not connected, in the sense that selecting one would be liable to lead to the selection of the others. To say that it would be obvious to progress from one selection to the next would, to my mind, be falling into the trap warned

against by Lord Diplock in *Technograph Circuits Ltd v Mills & Rockley (Electronics) Ltd* [1972] RPC 346, at 362. It would not be done without the benefit of hindsight.

424. Even if that were done, I do not believe it would have occurred to the skilled person to have either one set of wheels arranged fully within the vehicle body or to have a section in the shuttle vehicle for receiving the storage bin in the form of a centrally arranged cavity.
425. Claim 11 of EP 794 includes a robot in accordance with one of claims 1 to 10 and each of claims 2 to 9 is dependent on claim 1. Claim 1 of EP 027 has all of Professor Fottner's five features.

Conclusion on ten Hompel

426. Neither EP 794 nor EP 027 lacks inventive step over ten Hompel.

EP 824 and EP 481 – OCADO'S 400 and 500 BOTS

427. Ocado say that two of its Production Bots, the 400 Bots and 500 Bots, do not infringe either EP 824 or EP 481. They seek DNIs in respect of both patents and both robots. Ocado also run a squeeze: if their robots infringe, both patents are invalid, being obvious over PCT Application no. WO 2014/203126 A1 ("Lindbo 2"). In support of their case Ocado filed expert evidence from Professor Gerada.
428. AutoStore filed no evidence and advanced no case in relation to any of the issues of construction, non-infringement or validity arising from Ocado's case under this head. In closing AutoStore stated that if I were to be satisfied that Ocado's arguments on the construction of EP 824 and EP 481 were correct, AutoStore did not resist the granting of these DNIs.
429. However, AutoStore argued in its closing written submissions that this head of Ocado's case raised a point of principle. In *Fresenius Kabi Deutschland GmbH v Carefusion 303, Inc* [2011] EWHC 2959 (Pat), the patentee consented to an order for revocation of the UK patent but did not admit that the patent was invalid. The claimant sought to amend its pleading to seek an application for a declaration that the patent was invalid on the ground that such a declaration would be of benefit in other jurisdictions. Vos J refused the application. In his view it was not in accordance with the overriding objective for the court to waste time on issues which were academic in this jurisdiction on the ground that the outcome may have application in other jurisdictions (at [42]-[43]).
430. The facts in the present case are not the same. AutoStore has not consented to the revocation of either EP 824 or EP 781. Ocado's position is that if it they are correct on construction, those patents are not invalid although neither is infringed. I must decide whether Ocado is entitled to their DNIs. On the other hand, if yes, it would not be in accordance with the overriding objective for me to go on and decide whether either patent is invalid when neither side is inviting me to do so.

431. The specifications EP 824 and EP 781 are very similar. Two points of construction have been raised, one of them the same for both patents. I will consider first the point in common and will do so in relation to EP 824.

EP 824

432. EP 824 is for an invention entitled “A robot for transporting storage bins”. The specification refers to AutoStore’s prior art cantilever robots and continues:

“[0004] However, with this known system each vehicle is covering a cross section of the underlying storage system that corresponds to two storage columns, thereby limiting the maximum number of simultaneously operating vehicles.

[0005] It is thus an object of the present invention to provide a vehicle and a storage system that allows a significant increase in the number of simultaneously operating vehicles during successful handling of storage bins.”

433. This is claim 1. I have highlighted in bold the words which give rise to the point of construction:

“1. A remotely operated vehicle for picking up storage bins (2) from an underlying storage system, comprising

a vehicle lifting device for lifting the storage bin from the underlying storage system, a first vehicle rolling means comprising a first rolling set and a second rolling set arranged at opposite facing side walls of a vehicle body, allowing movement of the vehicle along a first direction (X) on the underlying storage system during use, and a second vehicle rolling means comprising a first rolling set and a second rolling set arranged at opposite facing side walls of the vehicle body, allowing movement of the vehicle along a second direction (Y) on the underlying storage system during use, the second direction (Y) being perpendicular to the first direction (X),

characterized in that the vehicle further comprises

a first driving means situated at or at least partly within the first vehicle rolling means **for providing rolling set specific driving force** to the vehicle in the first direction (X) and

a second driving means situated at or at least partly within the second vehicle rolling means **for providing rolling set specific driving force** to the vehicle in the second direction (Y) and at least one of the first and second driving means comprises rotor magnets arranged at the inner surface of the outer periphery of the vehicle rolling means and a stator enclosed by the outer periphery.”

434. The pre-characterising portion of claim 1 refers to a first and second rolling means. Both comprise two “rolling sets”, arranged on opposite sides of the

vehicle body. The first rolling means allow movement in the X direction, the second in the Y direction. Professor Gerada illustrated the rolling means:

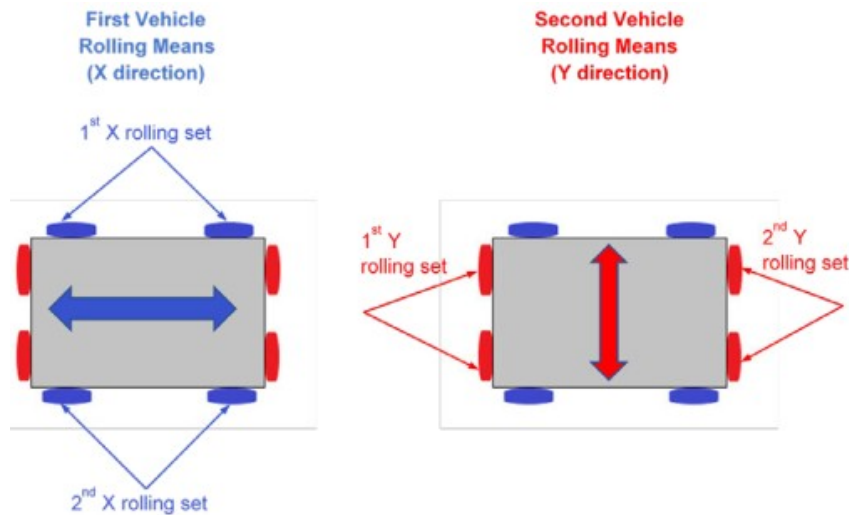

435. On Ocado’s construction a “rolling set specific driving force” is a force provided by one rolling set but not the other (of a single rolling means). Each of the first and second rolling sets must be suitable for providing such a side-specific force.
436. On AutoStore’s construction, the rolling set specific requirement goes only to the location of the motors and not whether they can be directed to drive the wheels on one side but not the other. The first and second driving means, the motors, each provide a rolling set specific driving force if each is located on one side of the robot.
437. A problem with AutoStore’s argument is that it is not consistent with its argument in EPO Opposition proceedings, in which AutoStore stated (Response of 30 November 2020 at para.5.2):

“However, the ‘rolling set specific driving force’ can allow the function of synchronizing the driving force in each rolling set. Should the driving force in each of these two rolling sets be unsynchronized, that would impose torque on the vehicle, causing it to attempt to turn on the tracks of the rails. That may additionally cause wear on the wheels and could result in vehicles clashing as they pass one another.”

438. This chimes with Professor Gerada’s unchallenged evidence that the reason and advantage of being able to have the driving force differentially applied to one side of the vehicle and not the other, is that the torque demanded on each side may not be the same. Where it is not, applying different torques can provide the same driving force on each side, avoiding the problems which AutoStore identified to the EPO.
439. I am satisfied that Ocado’s construction is the correct one. Given AutoStore’s concession in closing, it follows that Ocado are entitled to DNIs in relation to

their 400 and 500 Bots and there is no need for me to consider the second point of construction.

OVERALL CONCLUSION

440. EP 794 and EP 027 are both invalid due to prior disclosures in Russia. Neither is invalid over ten Hompel. Had they been valid, those patents would not have been infringed by the Production Bots of Ocado's OSP system, with or without cladding.
441. Ocado are entitled to a DNI in respect of its Mod 4A robot in relation to EP 794 and EP 027.
442. In relation to EP 794 and EP 027, Ocado are not entitled to the DNI sought in respect of its CSM.
443. In relation to EP 794, Ocado are entitled to the DNIs sought in respect of their 400 and 500 Bots (with and without cladding). In relation to EP 027, Ocado are entitled to the DNIs sought in respect of their OSP system when used with their 400 and/or 500 Bots (with or without cladding).
444. Ocado are entitled to DNIs in respect of their 400 and 500 Bots in relation to EPs 824 and 481.